

MOSC

Compressor rack

Installation instructions

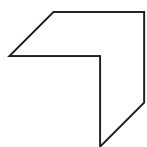

Cooling solutions, delivered with care.

www.frigabohn.com

Dimensional characteristics

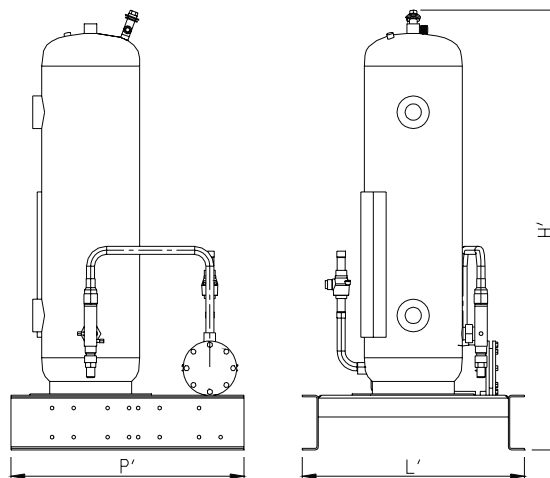
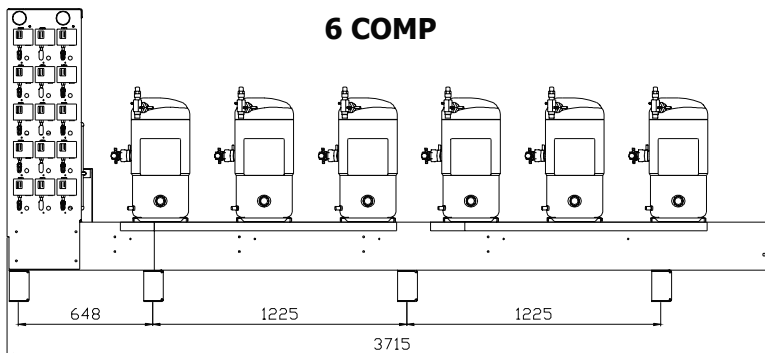
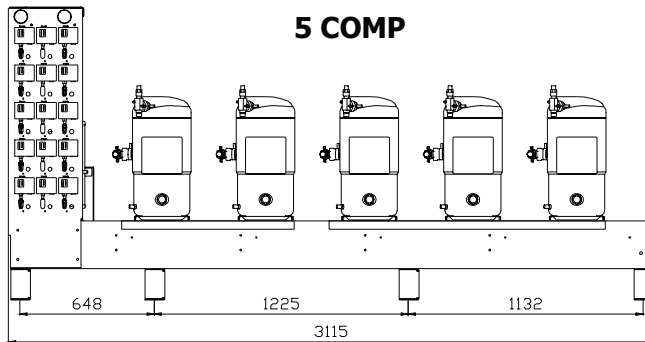
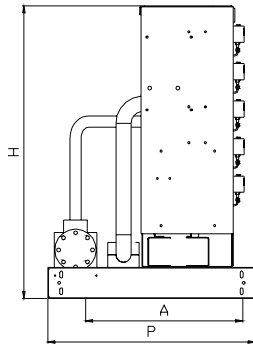

MOSC Positive

Model	H [mm]	P [mm]	A [mm]	L' [mm]	P' [mm]	H' [mm]	Weight liquid station [kg]
MOSC 64/5P	1400	800	655	650	620	1700	140
MOSC 90/5P	1400	800	655	650	620	1950	190
MOSC 108/6P	1400	1000	755	650	620	1950	190
MOSC 110/5P	1400	1000	755	650	620	1950	190
MOSC 129/5P	1400	1000	755	650	620	1750	230
MOSC 132/6P	1400	1000	755	650	620	1750	230
MOSC 154/6P	1400	1000	755	650	620	1750	230

MOSC Négative

Model	H [mm]	P [mm]	A [mm]	L' [mm]	P' [mm]	H' [mm]	Weight liquid station [kg]
20/5N	1400	800	655	650	620	1700	140
23/5N	1400	800	655	650	620	1700	140
28/6N	1400	1000	755	650	620	1950	190
35/5N	1400	1000	755	650	620	1750	230
38/5N	1400	1000	755	650	620	1750	230
42/6N	1400	1000	755	650	620	1750	230
45/6N	1400	1000	755	650	620	1750	230

Weight positive

Weight négative

Model	Compressor	Weight (Kg)	model	Compresseur	Weight (Kg)
64/5P	5 x ZB56	820	20/5N	5 x ZF24	820
30/5P	5 x ZB75	820	23/5N	5 x ZF33	820
110/5P	5 x ZB92	890	35/5N	5 x ZF40	890
129/5P	5 x ZB11	930	38/5N	5 x ZF48	930
108/6P	6 x ZB75	980	28/6N	6 x ZF33	980
132/6P	6 x ZB92	1040	42/6N	6 x ZF40	1040
154/6P	6 x ZB11	1100	45/6N	6 x ZF48	1100

Technical data

Positive

Négative

MODEL	Compressors	I max [A]	I dem [A]	P max [kW]	MODEL	Compressors	I max [A]	I dem [A]	P max [kW]
64/5P	5 x ZB56	80	163	40	20/5N	5 x ZF24	81	163	43
90/5P	5 x ZB75	110	222	61	23/5N	5 x ZF33	112	223	65
110/5P	5 x ZB92	125	269	68	35/5N	5 x ZF40	126	259	73
129/5P	5 x ZB11	150	307	83	38/5N	5 x ZF48	155	311	85
108/6P	6 x ZB75	132	244	73	28/6N	6 x ZF33	97	180	52
132/6P	6 x ZB92	150	294	82	42/6N	6 x ZF40	134	246	77
154/6P	6 x ZB11	180	337	99	45/6N	6 x ZF48	151	285	87

* Attention: Idem = maximum start current with timer for cascade start-up of compressors.
(The compressors do not all start at the same time).

Handling

When using a pallet truck or forklift truck, the unit must be handled from the front (compressor side).

Please refer to the associated commercial and/or software documentation for further details.

Appendix 1: Installation log sheet

Company:	Date			
Technician:				
Unit	Suction pressure	bar		
	Suction temperature	°C		
	Delivery pressure	bar		
	Power supply voltage (uu, uv, uw)	V		
	Cut-out value HP pressure switch	bar		
	Cut-out value LP pressure switch	bar		
Compressor 1	Input amperage (u, v, w)	A		
	Delivery temperature	°C		
	Crankcase heater in good working order	Y/N		
	Oil level (full ¾ ½ ¼)			
Compressor 2	Input amperage (u, v, w)	A		
	Delivery temperature	°C		
	Crankcase heater in good working order	Y/N		
	Oil level (full ¾ ½ ¼)			
Compressor 3	Input amperage (u, v, w)	A		
	Delivery temperature	°C		
	Crankcase heater in good working order	Y/N		
	Oil level (full ¾ ½ ¼)			
Compressor 4	Input amperage (u, v, w)	A		
	Delivery temperature	°C		
	Crankcase heater in good working order	Y/N		
	Oil level (full ¾ ½ ¼)			
Compressor 5	Input amperage (u, v, w)	A		
	Delivery temperature	°C		
	Crankcase heater in good working order	Y/N		
	Oil level (full ¾ ½ ¼)			
Compressor 6	Input amperage (u, v, w)	A		
	Delivery temperature	°C		
	Crankcase heater in good working order	Y/N		
	Oil level (full ¾ ½ ¼)			
Refrigerant Circuit	Presence of humidity	Y/N		
	Pump down working correctly	Y/N		
	Refrigerant safety devices working correctly	Y/N		
	Hoses in good state	Y/N		
	Circuit sealing	Y/N		
Electrical Cabinet	Connections properly tightened	Y/N		
	Electrical safety devices working correctly	Y/N		

Remarks:

Appendix 2 : Operating instructions for oil management system series "INT 280 -230V"



INT280® Oil level regulator

INT280®

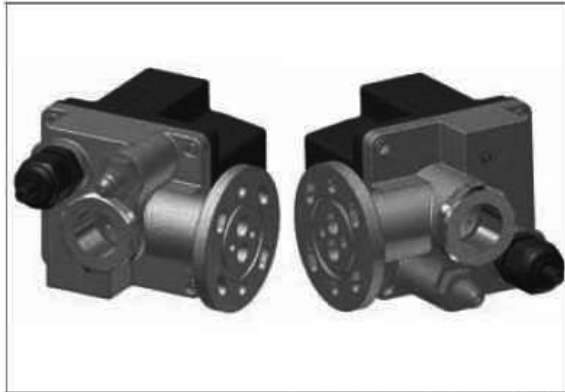

INT280 in the two mounting positions

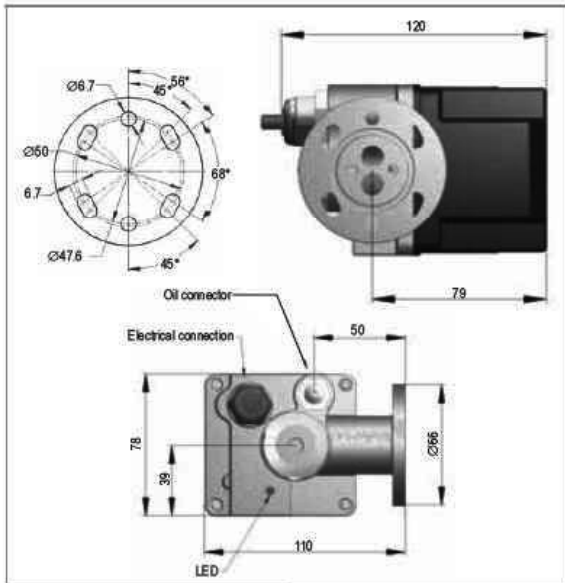

Dimensions in mm

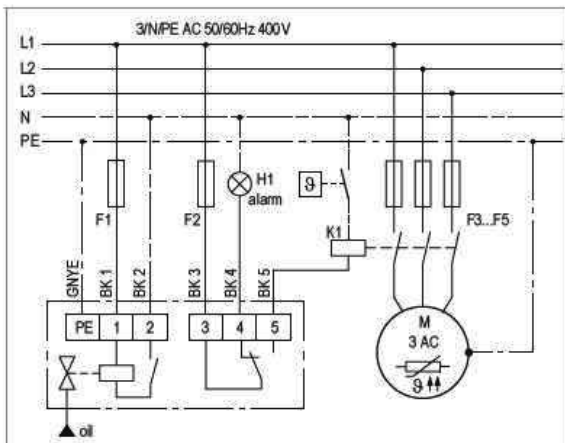

Wiring diagram (suggestion)

Application

The INT280 monitors and controls the oil level in the refrigerant compressors. In particular, the problem of bad oil distribution in multi-compressor packs is solved, thanks to active oil supply from a shared oil reservoir. The oil level regulator keeps the oil level at half the height of the sight glass.

Functional description

If the optical monitoring unit detects that the oil level is low, the integrated oil supply solenoid valve is activated by the electronics. Via the solenoid valve, oil is cyclically injected into the compressor crankcase. The INT280 generates an alarm signal and activates the relay output if the oil level is still too low after a defined period of time. During the "oil deficiency" alarm status, the electronics of the INT280 continues to operate the solenoid valve, in order to inject oil into the crankcase. The alarm status is automatically reset if the oil level is at half the height of the sight glass.

LED status display

Level OK	Green is continuously lit
Filling	Green flashes
Oil level too low	Red is continuously lit
Internal error	Red flashes

Installation instructions

The user has to ensure that the flange is properly tight. The electrical connection needs to be carried out according to the wiring diagram.

⚠ The unit must be connected by trained electrical personnel. All valid European and national standards for connecting electrical equipment must be observed.

Technical specifications

Supply voltage	AC 24V 50/60Hz ±10%, 15VA AC 115V 50/60Hz ±10%, 15VA AC 230V 50/60Hz ±10%, 15VA
Permitted ambient temperature	-30...+60°C
Medium temperature	-30...+100°C
Operating pressure	-1...46bar
Differential pressure	1...25bar (across valve)
Relay	AC 240V, 2.5A, C300
Mechanical service life	Approx. 10 ⁶ switching cycles
Protection class acc. to EN 60529	IP65
Connecting cable	6xAWG18 (0.75mm ²), length 1m
Housing material	Aluminium PA66/PA6, glass-fibre-reinforced
Flange connection	3-/4- hole flange
Oil connection	7/16"-20 UNF
Permitted oils	Standard mineral and ester oil, without additives
Permitted refrigerants	All non-corrosive standard refrigerants
Dimensions	Refer to dimensions
Weight	Approx. 950g
Order data	
AC 24V	31 S 381
AC 115V	41 S 381
AC 230V	52 S 381

KRIWAN

INT275 L® Level monitoring

INT275 L®

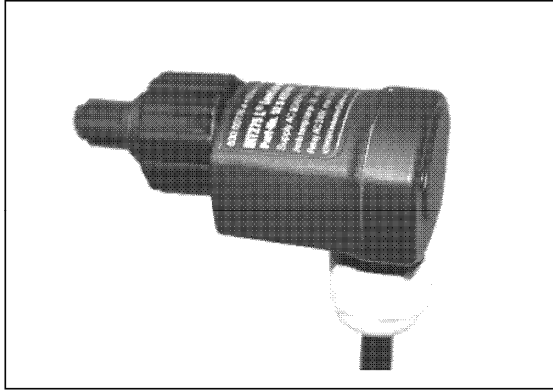

INT275 L

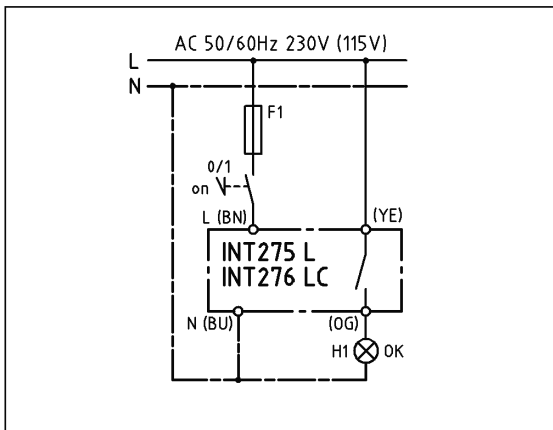

Connect on diagram

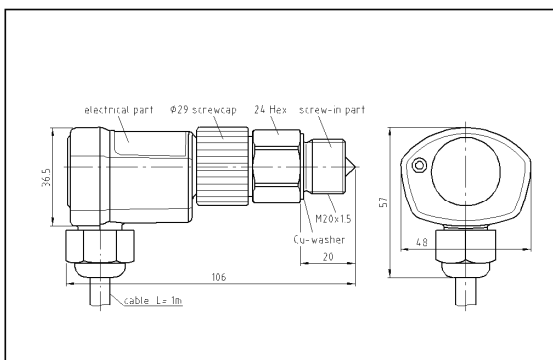

Dimensions in mm



The unit must be connected by trained electrical personnel. All valid standards for connecting elec-

trical equipment must be observed. Limit values for the supply voltage of the unit may not be exceeded.

Application:

The optical sensor INT275 L is developed for contactless level monitoring of liquids. A screw-in part mounted at the required location and a removable electrical part perform this function. The electrical part can be fitted or removed without opening the liquid tank. When the supply voltage is applied, the relay switches on after about 3s.

On absence of liquid or when a fault occurs the relay trips after a delay. When liquid is present or the fault disappears, the relay pulls in after a delay. The potential free normally open contact can be directly wired in a control circuit without an additional auxiliary relay. An integrated self-monitoring circuit ensures high reliability. A mounting check eliminates wrong installation or manipulation.

Installation instruction:

Mounting:

The installer must ensure seal tightness for the specific application. The maximum tightening torque is approx. 75Nm. Clean the inside of the screw-in part as well as the prism. Fit the electrical part in the screw-in part and tighten

the coupling ring (torque approx. 10Nm). Pay attention to the position of the lead (cable exit downwards). Complete the electrical wiring in accordance with the attached circuit suggestions. After filling the tank, check the tightness of all joints.

Technical data screw-in part

Ambient temperature range	-30...+60°C
Max. temperature at prism	+80°C
Test pressure	32bar
Housing	VA 1.4510 or 1.4305
Mounting	M20x1.5mm, wrench size 24 NPT1/2", wrench size 24
Weight	approx. 75g

Technical data electrical part

Supply voltage (52S...)	AC50/60Hz 230V ±10%
Supply voltage (41S...)	AC50/60Hz 115V ±10%
Ambient temperature range	-30...+60°C
Delays	
- Relay on after supply voltage on	3s±1s
Level monitoring active after	
Relay on	
Relay off (low level) after	5s±2s
Relay off (fault) after	5s±2s
Relay on (level high again) after	5s±2s
Relay on (fault disappears) after	5s±2s
Relay	AC250V, 2.5A, C300
Mechanical service life	approx. 10 ⁵ switching cycles
Housing	Ultradid A3XZG5
Protection class acc. to EN60529	IP54 when mounted
Mounting	coupling ring on screw-in part
Connecting cable	4xAWG18 (0.75mm ²) L=1m, colour-coded
Weight	approx. 80g

Ordering information

230V-Version: INT275 L Level monitoring	
Electrical Part	52S475S60
115V-Version: INT275 L Level monitoring	
Electrical Part	41S475S60
screw-in part M20x1.5mm	02K465
screw-in part NPT1/2"	02K460S22

Subject to technical modifications without notice

FRIGA-BOHN®



LFB France

42 rue Roger Salengro - BP 205
69741 GENAS CEDEX - FRANCE

Tél. : +33 4 72 47 13 00 - Fax : +33 4 72 47 13 96
www.frigabohn.com

Friga-Bohn se réserve le droit d'apporter toute modification sans préavis.
Friga-Bohn reserves itself the right to make changes at any time without preliminary notice.
Friga-Bohn Angaben und Abbildungen unverbindlich. Änderungen vorbehalten.
Friga-Bohn se reserva el derecho de aportar cualquier modificación sin preaviso
Friga-Bohn zastrzega sobie prawo do wprowadzania zmian bez uprzedzenia

MOSC

Compressor rack
N° IN0008300-F
04.2025