

MULTI HAVANE

Condensing units

Installation instructions

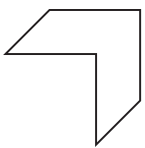

Cooling solutions, delivered with care.

www.frigabohn.com

Design features

OCTAGON range – POSITIF – 2 COMPRESSORS :

Model	Frame	Max operating current [A]	Starting current [A](*)	Power consumption [KW]	Weight [KG]	Suction valve	Liquid valve
MHV OCT 2P/4EC4 AS	C1 L2-6	26	69	16	830	1"5/8	7/8"
MHV OCT 2P/4EC4 A	C1 L2-5	23	65	14	790	1"5/8	7/8"
MHV OCT 2P/4EC4 ALN	C2 L2-A	23	65	13	1220	1"5/8	7/8"
MHV OCT 2P/4DC5 AS	C1 L2-6	32	80	19	890	1"5/8	7/8"
MHV OCT 2P/4DC5 A	C1 L2-6	32	80	19	890	1"5/8	7/8"
MHV OCT 2P/4DC5 ALN	C2 L2-A	28	77	16	1290	1"5/8	7/8"
MHV OCT 2P/4CC6 AS	C1 L3-6	35	102	19	970	1"5/8	7/8"
MHV OCT 2P/4CC6 A	C1 L2-6	36	103	21	910	1"5/8	7/8"
MHV OCT 2P/4CC6 ALN	C2 L2-A	37	103	20	1310	1"5/8	7/8"
MHV OCT 2P/4VC6 AS	C1 L3-6	35	89	20	1060	1"5/8	7/8"
MHV OCT 2P/4VC6 A	C1 L2-6	33	87	19	990	1"5/8	7/8"
MHV OCT 2P/4VC6 ALN	C2 L2-A	33	87	18	1390	1"5/8	7/8"
MHV OCT 2P/4TC8 AS	C1 L3-6	41	105	25	1020	2"1/8	1"1/8
MHV OCT 2P/4TC8 A	C1 L3-6	37	101	20	1010	2"1/8	1"1/8
MHV OCT 2P/4TC8 ALN	C2 L2-B	39	103	21	1540	2"1/8	1"1/8
MHV OCT 2P/4PC10 AS	C2 L2-A	54	132	29	1250	2"1/8	1"1/8
MHV OCT 2P/4PC10 A	C1 L3-6	49	127	29	1030	2"1/8	1"1/8
MHV OCT 2P/4PC10 ALN	C2 L2-B	47	125	25	1550	2"1/8	1"1/8
MHV OCT 2P/4NC12 AS	C2 L2-A	60	149	34	1310	2"1/8	1"1/8
MHV OCT 2P/4NC12 A	C2 L2-A	57	146	32	1260	2"1/8	1"1/8
MHV OCT 2P/4NC12 ALN	C2 L2-B	53	142	30	1560	2"1/8	1"1/8

OCTAGON range – POSITIF – 3 COMPRESSORS :

Model	Frame	Max operating current [A]	Starting current [A] (*)	Power consumption [KW]	Weight [KG]	Suction valve	Liquid valve
MHV OCT 3P/4EC4 AS	C3 L2-A	41	83	23	1540	1"5/8	7/8"
MHV OCT 3P/4EC4 A	C3 L2-A	41	83	23	1540	1"5/8	7/8"
MHV OCT 3P/4EC4 ALN	C3 L2-A	37	80	21	1740	1"5/8	7/8"
MHV OCT 3P/4DC5 AS	C3 L2-A	49	98	28	1560	2"1/8	1"1/8
MHV OCT 3P/4DC5 A	C3 L2-A	49	98	28	1500	2"1/8	1"1/8
MHV OCT 3P/4DC5 ALN	C3 L2-A	45	94	26	1700	2"1/8	1"1/8
MHV OCT 3P/4CC6 AS	C3 L2-A	60	126	32	1580	2"1/8	1"1/8
MHV OCT 3P/4CC6 A	C3 L2-A	56	123	31	1580	2"1/8	1"1/8
MHV OCT 3P/4CC6 ALN	C3 L3-A	55	122	30	1930	2"1/8	1"1/8
MHV OCT 3P/4VC6 AS	C3 L2-A	54	108	30	1750	2"1/8	1"1/8
MHV OCT 3P/4VC6 A	C3 L2-A	51	105	28	1700	2"1/8	1"1/8
MHV OCT 3P/4VC6 ALN	C3 L3-A	49	103	27	2050	2"1/8	1"1/8
MHV OCT 3P/4TC8 AS	C3 L2-B	63	127	34	1790	2"1/8	1"1/8
MHV OCT 3P/4TC8 A	C3 L2-A	63	127	34	1710	2"1/8	1"1/8
MHV OCT 3P/4TC8 ALN	C3 L3-A	55	119	30	2060	2"1/8	1"1/8
MHV OCT 3P/4PC10 AS	C3 L3-A	81	159	43	1970	2"5/8	1"3/8
MHV OCT 3P/4PC10 A	C3 L2-A	75	153	40	1810	2"5/8	1"3/8
MHV OCT 3P/4PC10 ALN	C3 L3-A	70	148	38	2150	2"5/8	1"3/8
MHV OCT 3P/4NC12 AS	C3 L3-A	90	179	50	2050	2"5/8	1"3/8
MHV OCT 3P/4NC12 A	C3 L2-B	84	173	48	1850	2"5/8	1"3/8
MHV OCT 3P/4NC12 ALN	C3 L3-A	79	168	45	2300	2"5/8	1"3/8

OCTAGON range – POSITIF – 4 COMPRESSORS :

Model	Frame	Max operating current [A]	Starting current [A] (*)	Power consumption [KW]	Weight [KG]	Suction valve	Liquid valve
MHV OCT 4P/4EC4 AS	C5 P4-A	45	88	27	2180	2"1/8	1"1/8
MHV OCT 4P/4EC4 A	C5 P4-A	45	87	26	2180	2"1/8	1"1/8
MHV OCT 4P/4EC4 ALN	C5 P4-A	45	87	26	2470	2"1/8	1"1/8
MHV OCT 4P/4DC5 A	C5 P4-A	57	105	33	2190	2"1/8	1"1/8
MHV OCT 4P/4DC5 ALN	C5 P4-A	57	105	33	2480	2"1/8	1"1/8
MHV OCT 4P/4DC5 AS	C5 P4-A	64	113	36	2260	2"1/8	1"1/8
MHV OCT 4P/4CC6 AS	C5 P4-A	68	135	38	2340	2"1/8	1"1/8
MHV OCT 4P/4CC6 A	C5 P4-A	73	140	40	2290	2"1/8	1"1/8
MHV OCT 4P/4CC6 ALN	C5 P4-A	73	140	40	2580	2"1/8	1"1/8
MHV OCT 4P/4VC6 AS	C5 P4-A	61	115	35	2490	2"5/8	1"1/8
MHV OCT 4P/4VC6 A	C5 P4-A	66	120	36	2440	2"5/8	1"1/8
MHV OCT 4P/4VC6 ALN	C5 P4-A	66	120	36	2730	2"5/8	1"1/8
MHV OCT 4P/4TC8 AS	C5 P4-A	85	149	46	2490	2"5/8	1"3/8
MHV OCT 4P/4TC8 A	C5 P4-A	73	137	40	2540	2"5/8	1"3/8
MHV OCT 4P/4TC8 ALN	C5 P4-A	73	137	40	2830	2"5/8	1"3/8
MHV OCT 4P/4PC10 AS	C5 P4-A	101	179	55	2560	2"5/8	1"3/8
MHV OCT 4P/4PC10 A	C5 P4-A	101	179	55	2510	2"5/8	1"3/8
MHV OCT 4P/4PC10 ALN	C5 P6-A	99	177	53	3110	2"5/8	1"3/8
MHV OCT 4P/4NC12 AS	C5 P4-A	113	202	64	2570	2"5/8	1"3/8
MHV OCT 4P/4NC12 A	C5 P4-A	113	202	64	2520	2"5/8	1"3/8
MHV OCT 4P/4NC12 ALN	C5 P6-A	111	200	62	3120	2"5/8	1"3/8

OCTAGON range – NEGATIF – 2 COMPRESSORS :

Model	Frame	Max operating current [A]	Starting current [A] (*)	Power consumption [KW]	Weight [KG]	Suction valve	Liquid valve
MHV OCT 2N/4EC4 AS	C1 L2-5	23	65	14	800	1"3/8	5/8"
MHV OCT 2N/4EC4 A	C1 L2-5	23	65	14	800	1"3/8	5/8"
MHV OCT 2N/4EC4 ALN	C1 L2-6	22	65	13	920	1"3/8	5/8"
MHV OCT 2N/4DC5 AS	C1 L2-5	28	77	17	800	1"3/8	5/8"
MHV OCT 2N/4DC5 A	C1 L2-5	28	77	17	800	1"3/8	5/8"
MHV OCT 2N/4DC5 ALN	C1 L2-6	28	77	16	920	1"3/8	5/8"
MHV OCT 2N/4CC6 AS	C1 L2-5	33	100	19	820	1"5/8	5/8"
MHV OCT 2N/4CC6 A	C1 L2-5	33	100	19	820	1"5/8	5/8"
MHV OCT 2N/4CC6 ALN	C1 L2-6	33	99	18	930	1"5/8	5/8"
MHV OCT 2N/4VC6 AS	C1 L2-5	29	83	17	900	1"5/8	5/8"
MHV OCT 2N/4VC6 A	C1 L2-5	29	83	17	900	1"5/8	5/8"
MHV OCT 2N/4VC6 ALN	C1 L2-6	29	83	17	1010	1"5/8	5/8"
MHV OCT 2N/4TC8 AS	C1 L2-6	36	100	20	1000	1"5/8	5/8"
MHV OCT 2N/4TC8 A	C1 L2-5	35	99	20	970	1"5/8	5/8"
MHV OCT 2N/4TC8 ALN	C1 L3-6	36	100	19	1150	1"5/8	5/8"
MHV OCT 2N/4PC10 AS	C1 L2-6	44	122	24	1010	1"5/8	5/8"
MHV OCT 2N/4PC10 A	C1 L2-6	44	122	24	1010	1"5/8	5/8"
MHV OCT 2N/4PC10 ALN	C1 L3-6	44	122	24	1160	1"5/8	5/8"
MHV OCT 2N/4NC12 AS	C1 L2-6	50	139	29	970	2"1/8	7/8"
MHV OCT 2N/4NC12 A	C1 L2-6	50	139	29	970	2"1/8	7/8"
MHV OCT 2N/4NC12 ALN	C2 L2-A	49	138	29	1380	2"1/8	7/8"

OCTAGON range – NEGATIF – 3 COMPRESSORS :

Model	Frame	Max operating current [A]	Starting current [A] (*)	Power consumption [KW]	Weight [KG]	Suction valve	Liquid valve
MHV OCT 3N/4EC4 AS	C3 L2-A	33	75	19	1390	1"5/8	5/8"
MHV OCT 3N/4EC4 A	C3 L2-A	33	75	19	1390	1"5/8	5/8"
MHV OCT 3N/4EC4 ALN	C3 L2-A	33	75	19	1530	1"5/8	5/8"
MHV OCT 3N/4DC5 AS	C3 L2-A	42	91	24	1460	1"5/8	5/8"
MHV OCT 3N/4DC5 A	C3 L2-A	42	91	24	1460	1"5/8	5/8"
MHV OCT 3N/4DC5 ALN	C3 L2-A	42	91	24	1600	1"5/8	5/8"
MHV OCT 3N/4CC6 AS	C3 L2-A	49	116	27	1480	1"5/8	5/8"
MHV OCT 3N/4CC6 A	C3 L2-A	49	116	27	1480	1"5/8	5/8"
MHV OCT 3N/4CC6 ALN	C3 L2-A	49	116	27	1620	1"5/8	5/8"
MHV OCT 3N/4VC6 AS	C3 L2-A	43	97	25	1600	2"1/8	5/8"
MHV OCT 3N/4VC6 A	C3 L2-A	43	97	25	1600	2"1/8	5/8"
MHV OCT 3N/4VC6 ALN	C3 L2-A	43	97	25	1740	2"1/8	5/8"
MHV OCT 3N/4TC8 A	C3 L2-A	52	116	29	1560	2"1/8	7/8"
MHV OCT 3N/4TC8 AS	C3 L2-A	56	120	31	1670	2"1/8	7/8"
MHV OCT 3N/4TC8 ALN	C3 L2-A	52	116	29	1870	2"1/8	7/8"
MHV OCT 3N/4PC10 AS	C3 L2-A	72	150	39	1690	2"1/8	7/8"
MHV OCT 3N/4PC10 A	C3 L2-A	72	150	39	1690	2"1/8	7/8"
MHV OCT 3N/4PC10 ALN	C3 L2-A	68	146	37	1890	2"1/8	7/8"
MHV OCT 3N/4NC12 AS	C3 L2-A	81	170	46	1690	2"1/8	7/8"
MHV OCT 3N/4NC12 A	C3 L2-A	81	170	46	1690	2"1/8	7/8"
MHV OCT 3N/4NC12 ALN	C3 L2-A	77	166	44	1890	2"1/8	7/8"

OCTAGON range – NEGATIF – 4 COMPRESSORS :

Model	Frame	Max operating current [A]	Starting current [A] (*)	Power consumption [KW]	Weight [KG]	Suction valve	Liquid valve
MHV OCT 4N/4EC4 AS	C5 P4-A	44	86	26	2270	1"5/8	5/8"
MHV OCT 4N/4EC4 A	C5 P4-A	44	86	26	2270	1"5/8	5/8"
MHV OCT 4N/4EC4 ALN	C5 P4-A	44	86	26	2560	1"5/8	5/8"
MHV OCT 4N/4DC5 AS	C5 P4-A	55	104	32	2220	2"1/8	7/8"
MHV OCT 4N/4DC5 A	C5 P4-A	55	104	32	2220	2"1/8	7/8"
MHV OCT 4N/4DC5 ALN	C5 P4-A	55	104	32	2510	2"1/8	7/8"
MHV OCT 4N/4CC6 AS	C5 P4-A	65	131	36	2240	2"1/8	7/8"
MHV OCT 4N/4CC6 A	C5 P4-A	65	131	36	2240	2"1/8	7/8"
MHV OCT 4N/4CC6 ALN	C5 P4-A	65	131	36	2530	2"1/8	7/8"
MHV OCT 4N/4VC6 AS	C5 P4-A	57	111	33	2400	2"1/8	7/8"
MHV OCT 4N/4VC6 A	C5 P4-A	57	111	33	2400	2"1/8	7/8"
MHV OCT 4N/4VC6 ALN	C5 P4-A	57	111	33	2690	2"1/8	7/8"
MHV OCT 4N/4TC8 AS	C5 P4-A	70	134	38	2420	2"1/8	7/8"
MHV OCT 4N/4TC8 A	C5 P4-A	70	134	38	2420	2"1/8	7/8"
MHV OCT 4N/4TC8 ALN	C5 P4-A	70	134	38	2710	2"1/8	7/8"
MHV OCT 4N/4PC10 AS	C5 P4-A	86	164	48	2450	2"5/8	1"1/8
MHV OCT 4N/4PC10 A	C5 P4-A	86	164	48	2450	2"5/8	1"1/8
MHV OCT 4N/4PC10 ALN	C5 P4-A	86	164	48	2740	2"5/8	1"1/8
MHV OCT 4N/4NC12 AS	C5 P4-A	99	188	57	2450	2"5/8	1"1/8
MHV OCT 4N/4NC12 A	C5 P4-A	99	188	57	2450	2"5/8	1"1/8
MHV OCT 4N/4NC12 ALN	C5 P4-A	99	188	57	2740	2"5/8	1"1/8

SCROLL range – POSITIF – 2 COMPRESSORS :

Model	Frame	Max operating current [A]	Starting current [A] (*)	Power consumption [KW]	Weight [KG]	Suction valve	Liquid valve
MHV SC 2P/ZB38 AS	C1 L2-6	28	81	12	730	1"5/8	7/8"
MHV SC 2P/ZB38 A	C1 L2-5	27	80	12	710	1"5/8	7/8"
MHV SC 2P/ZB38 ALN	C1 L3-6	27	80	12	880	1"5/8	7/8"
MHV SC 2P/ZB45 AS	C1 L2-6	28	89	14	740	1"5/8	7/8"
MHV SC 2P/ZB45 A	C1 L2-5	28	89	13	720	1"5/8	7/8"
MHV SC 2P/ZB45 ALN	C1 L3-6	28	89	13	890	1"5/8	7/8"
MHV SC 2P/ZB50 AS	C1 L2-6	34	119	17	850	1"5/8	7/8"
MHV SC 2P/ZB50 A	C1 L2-6	31	117	15	840	1"5/8	7/8"
MHV SC 2P/ZB50 ALN	C2 L2-A	31	116	15	1250	1"5/8	7/8"
MHV SC 2P/ZB66 AS	C1 L3-6	42	135	23	920	1"5/8	7/8"
MHV SC 2P/ZB66 A	C1 L2-6	40	133	20	850	1"5/8	7/8"
MHV SC 2P/ZB66 ALN	C2 L2-A	40	133	20	1250	1"5/8	7/8"
MHV SC 2P/ZB76 AS	C1 L3-6	48	145	26	880	2"1/8	7/8"
MHV SC 2P/ZB76 A	C1 L2-6	45	143	23	810	2"1/8	7/8"
MHV SC 2P/ZB76 ALN	C2 L2-A	46	143	23	1210	2"1/8	7/8"
MHV SC 2P/ZB95 AS	C2 L2-A	68	180	32	1100	2"1/8	1"1/8
MHV SC 2P/ZB95 A	C1 L3-6	60	172	28	870	2"1/8	1"1/8
MHV SC 2P/ZB95 ALN	C2 L2-B	61	173	29	1400	2"1/8	1"1/8
MHV SC 2P/ZB114 AS	C2 L2-A	79	219	37	1160	2"1/8	1"1/8
MHV SC 2P/ZB114 A	C1 L3-6	74	214	37	890	2"1/8	1"1/8
MHV SC 2P/ZB114 ALN	C2 L2-B	72	212	33	1410	2"1/8	1"1/8

SCROLL range – POSITIF – 3 COMPRESSORS :

Model	Frame	Max operating current [A]	Starting current [A] (*)	Power consumption [KW]	Weight [KG]	Suction valve	Liquid valve
MHV SC 3P/ZB38 AS	C3 L2-A	47	100	21	1430	1"5/8	7/8"
MHV SC 3P/ZB38 A	C3 L2-A	47	100	21	1430	1"5/8	7/8"
MHV SC 3P/ZB38 ALN	C3 L2-A	40	92	18	1630	1"5/8	7/8"
MHV SC 3P/ZB45 AS	C3 L2-A	48	109	23	1430	1"5/8	7/8"
MHV SC 3P/ZB45 A	C3 L2-A	48	109	23	1430	1"5/8	7/8"
MHV SC 3P/ZB45 ALN	C3 L2-A	44	105	21	1630	1"5/8	7/8"
MHV SC 3P/ZB50 AS	C3 L2-A	52	138	25	1490	2"1/8	1"1/8
MHV SC 3P/ZB50 A	C3 L2-A	52	138	25	1430	2"1/8	1"1/8
MHV SC 3P/ZB50 ALN	C3 L2-A	49	134	23	1630	2"1/8	1"1/8
MHV SC 3P/ZB66 AS	C3 L2-A	65	158	32	1490	2"1/8	1"1/8
MHV SC 3P/ZB66 A	C3 L2-A	61	155	30	1490	2"1/8	1"1/8
MHV SC 3P/ZB66 ALN	C3 L3-A	60	153	29	1840	2"1/8	1"1/8
MHV SC 3P/ZB76 AS	C3 L2-A	73	171	36	1570	2"1/8	1"1/8
MHV SC 3P/ZB76 A	C3 L2-A	70	167	35	1520	2"1/8	1"1/8
MHV SC 3P/ZB76 ALN	C3 L3-A	69	166	34	1870	2"1/8	1"1/8
MHV SC 3P/ZB95 AS	C3 L3-A	103	214	48	1730	2"5/8	1"1/8
MHV SC 3P/ZB95 A	C3 L2-A	97	208	46	1570	2"5/8	1"1/8
MHV SC 3P/ZB95 ALN	C3 L3-A	92	204	43	1870	2"5/8	1"1/8
MHV SC 3P/ZB114 AS	C3 L3-A	118	259	55	1820	2"5/8	1"3/8
MHV SC 3P/ZB114 A	C3 L2-B	112	253	52	1620	2"5/8	1"3/8
MHV SC 3P/ZB114 ALN	C3 L3-A	107	248	50	2020	2"5/8	1"3/8

SCROLL range – POSITIF – 4 COMPRESSORS :

Model	Frame	Max operating current [A]	Starting current [A] (*)	Power consumption [KW]	Weight [KG]	Suction valve	Liquid valve
MHV SC 4P/ZB50 AS	C5 P4-A	68	154	32	2180	2"1/8	1"1/8
MHV SC 4P/ZB50 A	C5 P4-A	61	146	29	2110	2"1/8	1"1/8
MHV SC 4P/ZB50 ALN	C5 P4-A	61	146	29	2400	2"1/8	1"1/8
MHV SC 4P/ZB66 AS	C5 P4-A	80	173	39	2180	2"1/8	1"1/8
MHV SC 4P/ZB66 A	C5 P4-A	75	168	37	2110	2"1/8	1"1/8
MHV SC 4P/ZB66 ALN	C5 P4-A	75	168	37	2400	2"1/8	1"1/8
MHV SC 4P/ZB76 AS	C5 P4-A	91	189	45	2260	2"5/8	1"1/8
MHV SC 4P/ZB76 A	C5 P4-A	91	189	45	2210	2"5/8	1"1/8
MHV SC 4P/ZB76 ALN	C5 P4-A	91	189	45	2500	2"5/8	1"1/8
MHV SC 4P/ZB95 AS	C5 P4-A	130	242	62	2230	2"5/8	1"3/8
MHV SC 4P/ZB95 A	C5 P4-A	123	235	59	2170	2"5/8	1"3/8
MHV SC 4P/ZB95 ALN	C5 P4-A	123	234	58	2570	2"5/8	1"3/8
MHV SC 4P/ZB114 AS	C5 P4-A	150	291	71	2390	2"5/8	1"3/8
MHV SC 4P/ZB114 A	C5 P4-A	150	291	71	2240	2"5/8	1"3/8
MHV SC 4P/ZB114 ALN	C5 P6-A	148	289	69	2840	2"5/8	1"3/8

SCROLL range – NEGATIF – 2 COMPRESSORS :

Model	Frame	Max operating current [A]	Starting current [A] (*)	Power consumption [KW]	Weight [KG]	Suction valve	Liquid valve
MHV SC 2N/ZF15 AS	C1 L2-5	21	75	12	700	1"3/8	5/8"
MHV SC 2N/ZF15 A	C1 L2-5	21	75	12	700	1"3/8	5/8"
MHV SC 2N/ZF15 ALN	C1 L2-6	21	75	12	820	1"3/8	5/8"
MHV SC 2N/ZF24 AS	C1 L2-5	34	117	18	830	1"5/8	5/8"
MHV SC 2N/ZF24 A	C1 L2-5	34	117	18	830	1"5/8	5/8"
MHV SC 2N/ZF24 ALN	C1 L2-6	33	116	17	940	1"5/8	5/8"
MHV SC 2N/ZF33 AS	C1 L2-6	47	152	26	950	2"1/8	5/8"
MHV SC 2N/ZF33 A	C1 L2-6	47	152	26	950	2"1/8	5/8"
MHV SC 2N/ZF33 ALN	C1 L3-6	46	151	25	1100	2"1/8	5/8"
MHV SC 2N/ZF40 AS	C1 L2-6	55	197	31	910	2"1/8	7/8"
MHV SC 2N/ZF40 A	C1 L2-6	55	197	31	910	2"1/8	7/8"
MHV SC 2N/ZF40 ALN	C2 L2-A	52	193	29	1310	2"1/8	7/8"
MHV SC 2N/ZF48 AS	C1 L3-6	65	232	35	980	2"1/8	7/8"
MHV SC 2N/ZF48 A	C1 L2-6	66	233	37	920	2"1/8	7/8"
MHV SC 2N/ZF48 ALN	C2 L2-A	66	234	36	1320	2"1/8	7/8"

SCROLL range – NEGATIF – 3 COMPRESSORS :

Model	Frame	Max operating current [A]	Starting current [A] (*)	Power consumption [KW]	Weight [KG]	Suction valve	Liquid valve
MHV SC 3N/ZF15 AS	C3 L2-A	31	85	17	1310	1"5/8	5/8"
MHV SC 3N/ZF15 A	C3 L2-A	31	85	17	1310	1"5/8	5/8"
MHV SC 3N/ZF15 ALN	C3 L2-A	31	85	17	1450	1"5/8	5/8"
MHV SC 3N/ZF24 AS	C3 L2-A	50	133	26	1490	2"1/8	5/8"
MHV SC 3N/ZF24 A	C3 L2-A	50	133	26	1490	2"1/8	5/8"
MHV SC 3N/ZF24 ALN	C3 L2-A	50	133	26	1630	2"1/8	5/8"
MHV SC 3N/ZF33 AS	C3 L2-A	76	180	41	1550	2"1/8	7/8"
MHV SC 3N/ZF33 A	C3 L2-A	76	180	41	1550	2"1/8	7/8"
MHV SC 3N/ZF33 ALN	C3 L2-A	72	177	39	1750	2"1/8	7/8"
MHV SC 3N/ZF40 AS	C3 L2-A	84	226	47	1580	2"5/8	7/8"
MHV SC 3N/ZF40 A	C3 L2-A	84	226	47	1580	2"5/8	7/8"
MHV SC 3N/ZF40 ALN	C3 L2-A	80	222	45	1780	2"5/8	7/8"
MHV SC 3N/ZF48 AS	C3 L2-A	100	268	55	1670	2"5/8	7/8"
MHV SC 3N/ZF48 A	C3 L2-A	100	268	55	1670	2"5/8	7/8"
MHV SC 3N/ZF48 ALN	C3 L3-A	99	267	54	2020	2"5/8	7/8"

SCROLL range – NEGATIF – 4 COMPRESSORS :

Model	Frame	Max operating current [A]	Starting current [A] (*)	Power consumption [KW]	Weight [KG]	Suction valve	Liquid valve
MHV SC 4N/ZF24 AS	C5 P4-A	66	149	34	2260	2"1/8	7/8"
MHV SC 4N/ZF24 A	C5 P4-A	66	149	34	2260	2"1/8	7/8"
MHV SC 4N/ZF24 ALN	C5 P4-A	66	149	34	2550	2"1/8	7/8"
MHV SC 4N/ZF33 AS	C5 P4-A	92	197	51	2270	2"5/8	7/8"
MHV SC 4N/ZF33 A	C5 P4-A	91	196	50	2270	2"5/8	7/8"
MHV SC 4N/ZF33 ALN	C5 P4-A	91	196	50	2560	2"5/8	7/8"
MHV SC 4N/ZF40 AS	C5 P4-A	105	247	58	2310	2"5/8	1"1/8
MHV SC 4N/ZF40 A	C5 P4-A	103	245	58	2310	2"5/8	1"1/8
MHV SC 4N/ZF40 ALN	C5 P4-A	103	245	58	2600	2"5/8	1"1/8
MHV SC 4N/ZF48 AS	C5 P4-A	132	300	72	2380	2"5/8	1"1/8
MHV SC 4N/ZF48 A	C5 P4-A	132	300	72	2380	2"5/8	1"1/8
MHV SC 4N/ZF48 ALN	C5 P4-A	132	300	72	2730	2"5/8	1"1/8

Semi-hermetic range (COPELAND-BITZER) – POSITIF – 2 COMPRESSORS :

Model	Frame	Max operating current [A]	Starting current [A] (*)	Power consumption [KW]	Weight [KG]	Suction valve	Liquid valve
MHV SH 2P/4J13 AS	C3 L2-B	66	171	37	1730	2"5/8	1"1/8
MHV SH 2P/4J13 A	C3 L2-A	66	171	37	1650	2"5/8	1"1/8
MHV SH 2P/4J13 ALN	C3 L2-B	59	164	33	2000	2"5/8	1"1/8
MHV SH 2P/D4DA200 AS	C3 L2-A	77	220	43	1750	2"5/8	1"1/8
MHV SH 2P/D4DA200 A	C3 L2-A	74	216	41	1700	2"5/8	1"1/8
MHV SH 2P/D4DA200 ALN	C3 L2-B	70	212	39	2050	2"5/8	1"1/8
MHV SH 2P/4H15 AS	C3 L2-B	74	175	42	1830	2"5/8	1"1/8
MHV SH 2P/4H15 A	C3 L2-A	74	175	42	1700	2"5/8	1"1/8
MHV SH 2P/4H15 ALN	C4 P4-A	72	173	40	2380	2"5/8	1"1/8
MHV SH 2P/D4DH250 AS	C3 L2-B	95	253	50	1890	2"5/8	1"1/8
MHV SH 2P/D4DH250 A	C3 L2-A	95	253	50	1760	2"5/8	1"1/8
MHV SH 2P/D4DH250 ALN	C4 P4-A	93	250	49	2430	2"5/8	1"1/8
MHV SH 2P/4G20 AS	C3 L2-D	86	207	48	2000	3"1/8	1"3/8
MHV SH 2P/4G20 A	C3 L2-B	86	207	48	1890	3"1/8	1"3/8
MHV SH 2P/4G20 ALN	C4 P4-A	84	205	47	2480	3"1/8	1"3/8
MHV SH 2P/D4DJ300 AS	C3 L2-D	117	286	60	2040	3"1/8	1"3/8
MHV SH 2P/D4DJ300 A	C3 L2-B	117	286	60	1940	3"1/8	1"3/8
MHV SH 2P/D4DJ300 ALN	C4 P4-A	115	283	59	2530	3"1/8	1"3/8
MHV SH 2P/6H25 AS	C4 P4-A	107	255	62	2420	3"1/8	1"5/8
MHV SH 2P/6H25 A	C4 P4-A	107	255	62	2370	3"1/8	1"5/8
MHV SH 2P/6H25 ALN	C4 P6-A	105	253	60	2920	3"1/8	1"5/8
MHV SH 2P/D6DH350 AS	C4 P4-A	144	385	75	2410	3"1/8	1"5/8
MHV SH 2P/D6DH350 A	C4 P4-A	144	385	75	2360	3"1/8	1"5/8
MHV SH 2P/D6DH350 ALN	C4 P6-A	142	382	73	2910	3"1/8	1"5/8
MHV SH 2P/6G30 AS	C4 P4-A	130	297	74	2530	4"1/8	1"5/8
MHV SH 2P/6G30 A	C4 P4-A	130	297	74	2380	4"1/8	1"5/8
MHV SH 2P/6G30 ALN	C4 P4-D	116	283	68	3000	4"1/8	1"5/8
MHV SH 2P/D6DJ400 AS	C4 P4-A	190	411	96	2580	4"1/8	1"5/8
MHV SH 2P/D6DJ400 A	C4 P4-A	190	411	96	2430	4"1/8	1"5/8
MHV SH 2P/D6DJ400 ALN	C4 P4-D	176	397	90	3050	4"1/8	1"5/8
MHV SH 2P/6F40 AS	C4 P6-A	182	427	89	2800	4"1/8	1"5/8
MHV SH 2P/6F40 A	C4 P4-B	180	425	88	2580	4"1/8	1"5/8
MHV SH 2P/D6SU400 AS	C4 P6-A	182	408	98	2880	4"1/8	1"5/8
MHV SH 2P/D6SU400 A	C4 P4-B	180	406	97	2670	4"1/8	1"5/8

Semi-hermetic range (COPELAND-BITZER) – POSITIF – 3 COMPRESSORS :

Model	Frame	Max operating current [A]	Starting current [A] (*)	Power consumption [KW]	Weight [KG]	Suction valve	Liquid valve
MHV SH 3P/4J13 AS	C5 P4-A	105	210	58	2550	3"1/8	1"3/8
MHV SH 3P/4J13 A	C5 P4-A	91	196	52	2520	3"1/8	1"3/8
MHV SH 3P/4J13 ALN	C5 P6-A	96	201	53	3140	3"1/8	1"3/8
MHV SH 3P/D4DA200 AS	C5 P4-A	115	257	64	2600	3"1/8	1"3/8
MHV SH 3P/D4DA200 A	C5 P4-A	108	250	7	2580	3"1/8	1"3/8
MHV SH 3P/D4DA200 ALN	C5 P6-A	112	255	62	3200	3"1/8	1"3/8
MHV SH 3P/4H15 AS	C5 P4-A	110	211	62	2610	3"1/8	1"3/8
MHV SH 3P/4H15 A	C5 P4-A	110	211	62	2560	3"1/8	1"3/8
MHV SH 3P/4H15 ALN	C5 P6-A	108	209	60	3160	3"1/8	1"3/8
MHV SH 3P/D4DH250 AS	C5 P4-A	142	299	75	2690	3"1/8	1"3/8
MHV SH 3P/D4DH250 A	C5 P4-A	142	299	75	2640	3"1/8	1"3/8
MHV SH 3P/D4DH250 ALN	C5 P6-A	139	297	73	3230	3"1/8	1"3/8
MHV SH 3P/4G20 AS	C5 P4-A	135	256	75	2770	4"1/8	1"5/8
MHV SH 3P/4G20 A	C5 P4-A	135	256	75	2620	4"1/8	1"5/8
MHV SH 3P/4G20 ALN	C5 P6-A	126	247	70	3290	4"1/8	1"5/8
MHV SH 3P/D4DJ300 AS	C5 P4-B	182	350	93	2850	4"1/8	1"5/8
MHV SH 3P/D4DJ300 A	C5 P4-A	182	350	93	2680	4"1/8	1"5/8
MHV SH 3P/D4DJ300 ALN	C5 P6-A	172	341	88	3350	4"1/8	1"5/8
MHV SH 3P/6H25 AS	C5 P6-A	171	319	98	3210	4"1/8	1"5/8
MHV SH 3P/6H25 A	C5 P4-B	159	307	92	2920	4"1/8	1"5/8
MHV SH 3P/D6DH350 AS	C5 P6-A	227	467	117	3270	4"1/8	1"5/8
MHV SH 3P/D6DH350 A	C5 P4-B	215	455	111	2980	4"1/8	1"5/8
MHV SH 3P/6G30 AS	C5 P6-B	195	362	112	3370	4"1/8	1"5/8
MHV SH 3P/6G30 A	C5 P6-A	185	352	108	3170	4"1/8	1"5/8
MHV SH 3P/D6DJ400 AS	C5 P6-B	285	506	144	3470	4"1/8	1"5/8
MHV SH 3P/D6DJ400 A	C5 P6-A	275	496	140	3270	4"1/8	1"5/8
MHV SH 3P/6F40 AS	C5 P6-B	270	515	132	3450	4"1/8	2"1/8
MHV SH 3P/6F40 A	C5 P6-A	270	515	132	3330	4"1/8	2"1/8
MHV SH 3P/D6SU400 AS	C5 P6-B	270	496	146	3570	4"1/8	2"1/8
MHV SH 3P/D6SU400 A	C5 P6-A	270	496	146	3450	4"1/8	2"1/8

Semi-hermetic range (COPELAND-BITZER) – POSITIF HIGHT TEMPERATURE – 2 COMPRESSORS :

Model	Frame	Max operating current [A]	Starting current [A] (*)	Power consumption [KW]	Weight [KG]	Suction valve	Liquid valve
MHV SH 2PHT/4H25 AS	C4 P4-A	107	255	51	2290	2"5/8	1"3/8
MHV SH 2PHT/4H25 A	C3 L2-D	102	250	49	2040	2"5/8	1"3/8
MHV SH 2PHT/D4DH250 AS	C4 P4-A	100	251	53	2300	2"5/8	1"3/8
MHV SH 2PHT/D4DH250 A	C3 L2-D	95	246	50	2050	2"5/8	1"3/8
MHV SH 2PHT/4G30 AS	C4 P4-B	130	297	61	2410	3"1/8	1"5/8
MHV SH 2PHT/4G30 A	C4 P4-A	130	297	61	2240	3"1/8	1"5/8
MHV SH 2PHT/D4DJ300 AS	C4 P4-A	128	294	66	2430	3"1/8	1"5/8
MHV SH 2PHT/D4DJ300 A	C4 P4-A	128	294	66	2280	3"1/8	1"5/8
MHV SH 2PHT/6H35 AS	C4 P6-A	148	349	77	2800	3"1/8	1"5/8
MHV SH 2PHT/6H35 A	C4 P6-A	148	349	77	2800	3"1/8	1"5/8
MHV SH 2PHT/D6DH350 AS	C4 P6-A	153	381	79	2790	3"1/8	1"5/8
MHV SH 2PHT/D6DH350 A	C4 P6-A	153	381	79	2790	3"1/8	1"5/8
MHV SH 2PHT/6G40 AS	C4 P6-A	192	437	91	2880	4"1/8	2"1/8
MHV SH 2PHT/6G40 A	C4 P6-A	182	427	87	2810	4"1/8	2"1/8
MHV SH 2PHT/D6DJ400 AS	C4 P6-A	202	456	102	2930	4"1/8	2"1/8
MHV SH 2PHT/D6DJ400 A	C4 P6-A	192	446	98	2860	4"1/8	2"1/8
MHV SH 2PHT/6F50 AS	C4 P6-B	220	532	109	3010	4"1/8	2"1/8
MHV SH 2PHT/6F50 A	C4 P6-A	220	532	109	2890	4"1/8	2"1/8
MHV SH 2PHT/D6SK500 AS	C4 P6-B	225	546	113	3100	4"1/8	2"1/8
MHV SH 2PHT/D6SK500 A	C4 P6-A	215	536	109	2900	4"1/8	2"1/8

Semi-hermetic range (COPELAND-BITZER) – POSITIF HIGHT TEMPERATURE – 3 COMPRESSORS :

Model	Frame	Max operating current [A]	Starting current [A] (*)	Power consumption [KW]	Weight [KG]	Suction valve	Liquid valve
MHV SH 3PHT/4H25 AS	C5 P6-A	161	309	77	3030	3"1/8	1"5/8
MHV SH 3PHT/4H25 A	C5 P4-A	159	307	75	2800	3"1/8	1"5/8
MHV SH 3PHT/D4DH250 AS	C5 P6-A	150	301	79	3050	3"1/8	1"5/8
MHV SH 3PHT/D4DH250 A	C5 P4-B	149	299	78	2830	3"1/8	1"5/8
MHV SH 3PHT/4G30 AS	C5 P6-A	195	362	91	3110	4"1/8	2"1/8
MHV SH 3PHT/4G30 A	C5 P6-A	185	352	87	3040	4"1/8	2"1/8
MHV SH 3PHT/D4DJ300 AS	C5 P6-A	192	358	98	3160	4"1/8	2"1/8
MHV SH 3PHT/D4DJ300 A	C5 P6-A	182	348	95	3090	4"1/8	2"1/8
MHV SH 3PHT/6H35 A	C5 P6-B	219	420	113	3320	4"1/8	2"1/8
MHV SH 3PHT/D6DH350 A	C5 P6-B	227	455	117	3390	4"1/8	2"1/8
MHV SH 3PHT/6G40 A	C5 P6-B	270	515	128	3330	4"1/8	2"1/8
MHV SH 3PHT/D6DJ400 A	C5 P6-B	285	539	144	3470	4"1/8	2"1/8

Semi-hermetic range (COPELAND-BITZER) – NEGATIF – 2 COMPRESSORS :

Model	Frame	Max operating current [A]	Starting current [A] (*)	Power consumption [KW]	Weight [KG]	Suction valve	Liquid valve
MHV SH 2N/4H15 AS	C3 L2-A	71	172	40	1640	2"5/8	7/8"
MHV SH 2N/4H15 A	C3 L2-A	71	172	40	1640	2"5/8	7/8"
MHV SH 2N/4H15 ALN	C3 L2-A	67	168	38	1840	2"5/8	7/8"
MHV SH 2N/D4DL150 AS	C3 L2-A	66	193	34	1670	2"5/8	7/8"
MHV SH 2N/D4DL150 A	C3 L2-A	66	193	34	1670	2"5/8	7/8"
MHV SH 2N/D4DL150 ALN	C3 L2-A	62	189	32	1870	2"5/8	7/8"
MHV SH 2N/4G20 AS	C3 L2-A	83	204	47	1730	2"5/8	1"1/8
MHV SH 2N/4G20 A	C3 L2-A	83	204	47	1730	2"5/8	1"1/8
MHV SH 2N/4G20 ALN	C3 L2-A	79	200	45	1870	2"5/8	1"1/8
MHV SH 2N/D4DT220 AS	C3 L2-A	75	217	41	1760	2"5/8	1"1/8
MHV SH 2N/D4DT220 A	C3 L2-A	75	217	41	1760	2"5/8	1"1/8
MHV SH 2N/D4DT220 ALN	C3 L2-A	71	213	39	1900	2"5/8	1"1/8
MHV SH 2N/6H25 AS	C4 P4-A	100	248	58	2270	2"5/8	1"3/8
MHV SH 2N/6H25 A	C4 P4-A	100	248	58	2270	2"5/8	1"3/8
MHV SH 2N/6H25 ALN	C4 P4-A	93	241	55	2510	2"5/8	1"3/8
MHV SH 2N/D6DL270 AS	C4 P4-A	96	252	51	2260	2"5/8	1"3/8
MHV SH 2N/D6DL270 A	C4 P4-A	96	252	51	2260	2"5/8	1"3/8
MHV SH 2N/D6DL270 ALN	C4 P4-A	89	245	48	2500	2"5/8	1"3/8
MHV SH 2N/6G30 AS	C4 P4-A	116	283	68	2280	3"1/8	1"3/8
MHV SH 2N/6G30 A	C4 P4-A	116	283	68	2280	3"1/8	1"3/8
MHV SH 2N/6G30 ALN	C4 P4-A	116	283	68	2580	3"1/8	1"3/8
MHV SH 2N/D6DT300 AS	C4 P4-A	116	318	63	2330	3"1/8	1"3/8
MHV SH 2N/D6DT300 A	C4 P4-A	116	318	63	2330	3"1/8	1"3/8
MHV SH 2N/D6DT300 ALN	C4 P4-A	116	318	63	2630	3"1/8	1"3/8
MHV SH 2N/6F40 AS	C4 P4-A	166	411	81	2330	3"1/8	1"3/8
MHV SH 2N/6F40 A	C4 P4-A	166	411	81	2330	3"1/8	1"3/8
MHV SH 2N/6F40 ALN	C4 P4-A	166	411	81	2630	3"1/8	1"3/8
MHV SH 2N/D6SU400 AS	C4 P4-A	166	392	90	2410	3"1/8	1"3/8
MHV SH 2N/D6SU400 A	C4 P4-A	166	392	90	2410	3"1/8	1"3/8
MHV SH 2N/D6SU400 ALN	C4 P4-A	166	392	90	2710	3"1/8	1"3/8

Semi-hermetic range (COPELAND-BITZER) – NEGATIF – 3 COMPRESSORS :

Model	Frame	Max operating current [A]	Starting current [A] (*)	Power consumption [KW]	Weight [KG]	Suction valve	Liquid valve
MHV SH 3N/4H15 AS	C5 P4-A	103	204	58	2490	2"5/8	1"3/8
MHV SH 3N/4H15 A	C5 P4-A	103	204	58	2490	2"5/8	1"3/8
MHV SH 3N/4H15 ALN	C5 P4-A	96	197	55	2780	2"5/8	1"3/8
MHV SH 3N/D4DL150 AS	C5 P4-A	95	237	50	2530	2"5/8	1"3/8
MHV SH 3N/D4DL150 A	C5 P4-A	95	223	50	2530	2"5/8	1"3/8
MHV SH 3N/D4DL150 ALN	C5 P4-A	88	216	47	2820	2"5/8	1"3/8
MHV SH 3N/4G20 AS	C5 P4-A	121	242	68	2580	3"1/8	1"3/8
MHV SH 3N/4G20 A	C5 P4-A	121	242	68	2580	3"1/8	1"3/8
MHV SH 3N/4G20 ALN	C5 P4-A	121	242	68	2940	3"1/8	1"3/8
MHV SH 3N/D4DT220 AS	C5 P4-A	109	251	59	2630	3"1/8	1"3/8
MHV SH 3N/D4DT220 A	C5 P4-A	109	251	59	2630	3"1/8	1"3/8
MHV SH 3N/D4DT220 ALN	C5 P4-A	109	251	59	2980	3"1/8	1"3/8
MHV SH 3N/6H25 AS	C5 P4-A	145	293	86	2710	4"1/8	1"5/8
MHV SH 3N/6H25 A	C5 P4-A	145	293	86	2710	4"1/8	1"5/8
MHV SH 3N/6H25 ALN	C5 P4-A	140	288	84	3110	4"1/8	1"5/8
MHV SH 3N/D6DL270 AS	C5 P4-A	139	295	74	2740	4"1/8	1"5/8
MHV SH 3N/D6DL270 A	C5 P4-A	139	295	74	2740	4"1/8	1"5/8
MHV SH 3N/D6DL270 ALN	C5 P4-A	134	290	73	3140	4"1/8	1"5/8
MHV SH 3N/6G30 AS	C5 P4-A	176	343	104	2840	4"1/8	1"5/8
MHV SH 3N/6G30 A	C5 P4-A	176	343	104	2840	4"1/8	1"5/8
MHV SH 3N/6G30 ALN	C5 P6-A	174	341	102	3440	4"1/8	1"5/8
MHV SH 3N/D6DT300 AS	C5 P4-A	177	378	96	2920	4"1/8	1"5/8
MHV SH 3N/D6DT300 A	C5 P4-A	177	378	96	2920	4"1/8	1"5/8
MHV SH 3N/D6DT300 ALN	C5 P6-A	174	376	94	3520	4"1/8	1"5/8
MHV SH 3N/6F40 AS	C5 P4-A	251	496	124	2890	4"1/8	1"5/8
MHV SH 3N/6F40 A	C5 P4-A	251	496	124	2890	4"1/8	1"5/8
MHV SH 3N/6F40 ALN	C5 P6-A	249	494	122	3490	4"1/8	1"5/8
MHV SH 3N/D6SU400 AS	C5 P4-A	251	477	138	3020	4"1/8	1"5/8
MHV SH 3N/D6SU400 A	C5 P4-A	251	477	138	3020	4"1/8	1"5/8
MHV SH 3N/D6SU400 ALN	C5 P6-A	249	475	135	3610	4"1/8	1"5/8

(*) : Caution : Idem = maximum start current with timer for cascade start-up of compressors. (The compressors do not all start at the same time).

Dimensional specification

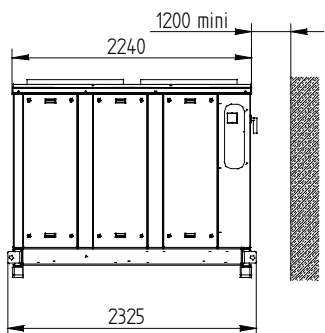
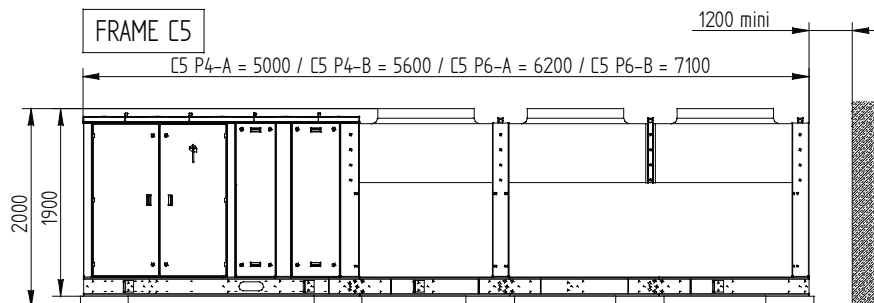
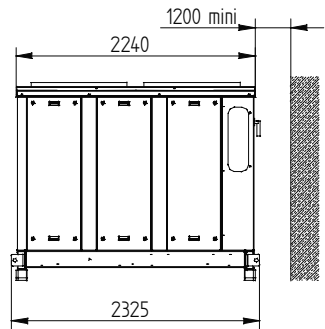
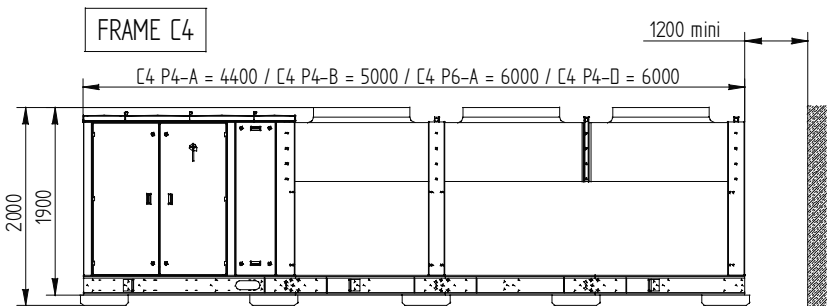
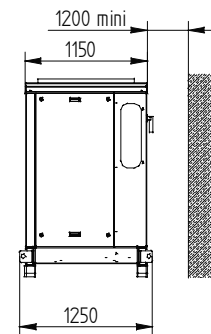
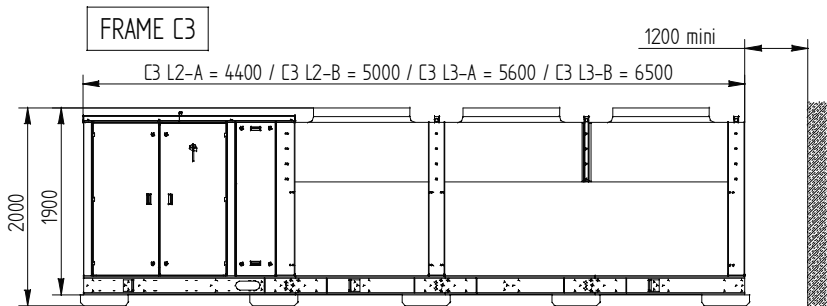
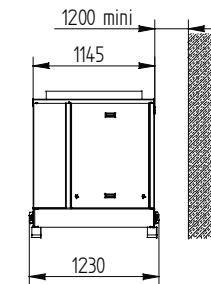
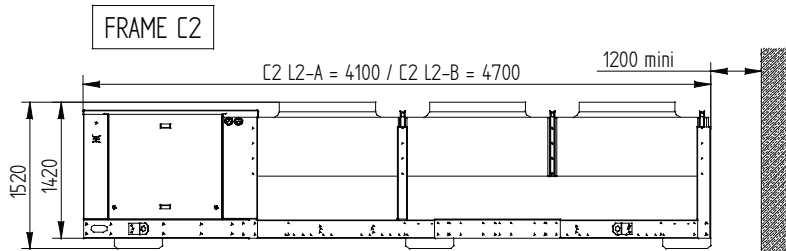
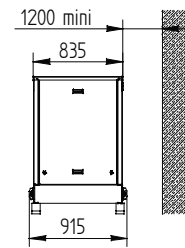
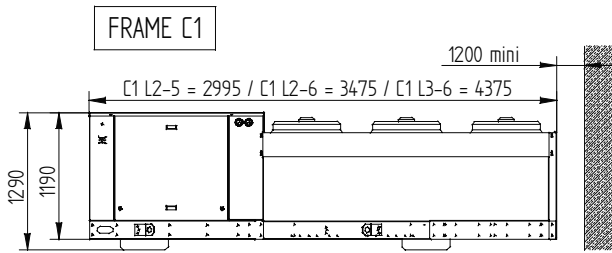

Fitting

The installation of these groups of condensation must be fitted on a perfectly plane flagstone without using an anti-vibratory system.

Handling

The group of condensation is delivered with wooden wedges , it can be moved with a lifting truck but you must to protect the casing before.

The unloading operation must be carried out with suitable equipment (crane, forklift truck...).

Removable lifting rings are available on the equipment for handling with a crane (see picture).

The equipment must be handled with care to avoid to damage the casing.

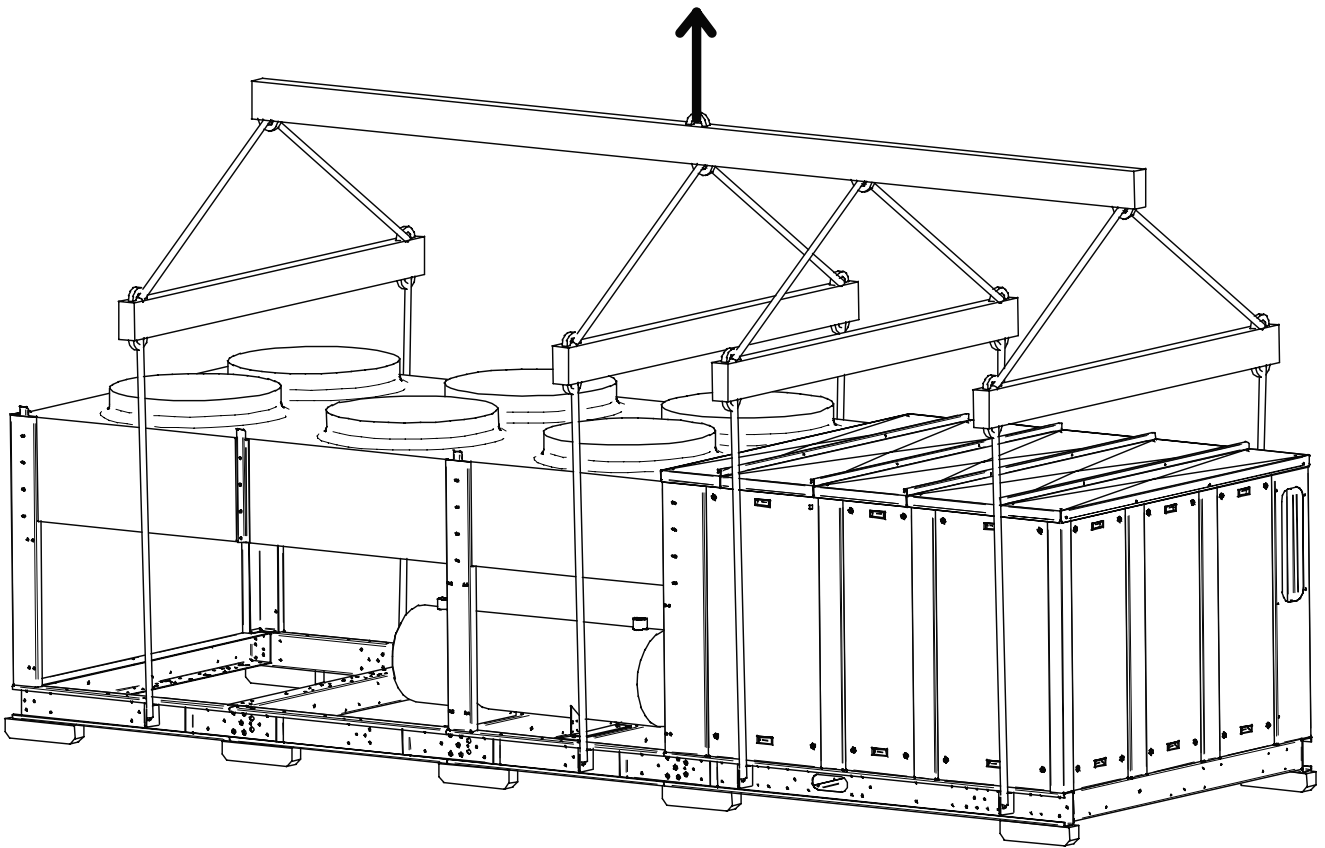

Please refer to the associated commercial and/or software documentation for further details.

Appendix 1: Installation log sheet

Company:		Date			
Technician:					
Unit	Suction pressure	bar			
	Suction temperature	°C			
	Delivery pressure	bar			
	Power supply voltage (uu, uv, uw)	V			
	Cut-out value HP pressure switch	bar			
	Cut-out value LP pressure switch	bar			
Compressor 1	Input amperage (u, v, w)	A			
	Delivery temperature	°C			
	Crankcase heater in good working order	Y/N			
	Oil level (full ¾ ½ ¼)				
Compressor 2	Input amperage (u, v, w)	A			
	Delivery temperature	°C			
	Crankcase heater in good working order	Y/N			
	Oil level (full ¾ ½ ¼)				
Compressor 3	Input amperage (u, v, w)	A			
	Delivery temperature	°C			
	Crankcase heater in good working order	Y/N			
	Oil level (full ¾ ½ ¼)				
Compressor 4	Input amperage (u, v, w)	A			
	Delivery temperature	°C			
	Crankcase heater in good working order	Y/N			
	Oil level (full ¾ ½ ¼)				
Refrigerant Circuit	Presence of humidity	Y/N			
	Pump down working correctly	Y/N			
	Refrigerant safety devices working correctly	Y/N			
	Hoses in good state	Y/N			
	Circuit sealing	Y/N			
Electrical Cabinet	Connections properly tightened	Y/N			
	Electrical safety devices working correctly	Y/N			

Remarks:

Appendix 2 : Bitzer operating instructions for oil level control OLC-K1

für

4VCS-6.2(Y) .. 4NCS-20.2(Y)
ab Seriennummer 166811090

4FC-3.2(Y) .. 4CC-9.2(Y)
mit speziellem Lagerdeckel

for

4VCS-6.2(Y) .. 4NCS-20.2(Y)
from serial number 166811090

4FC-3.2(Y) .. 4CC-9.2(Y)
with special bearing cover

pour

4VCS-6.2(Y) .. 4NCS-20.2(Y)
à partir du no. de série 166811090

4FC-3.2(Y) .. 4CC-9.2(Y)
avec couvercle de palier spécial

Inhalt

- 1 Anwendung
- 2 Technische Merkmale
- 3 Elektrischer Anschluss
- 4 Montage

1 Anwendung

Für die Lebensdauer eines Verdichters ist ausreichende Ölversorgung sehr wichtig. Ein Ausfall der Schmierung z. B. durch Ölmenge kann zu schweren Schäden am Triebwerk führen.

Das neu entwickelte Schutzsystem OLC-K1 überwacht die Ölversorgung von Verdichtern mit Zentrifugalschmierung. Dieses System wird besonders für Anlagen mit weitverzweigtem Rohrnetz empfohlen oder in Anwendungen, bei denen sich größere Mengen Öl zur Niederdruckseite verlagern können (z. B. kritische Strömungsgeschwindigkeiten bei Teillast).

Die Ölversorgung des Verdichters wird direkt im Bereich der Ölzufuhr zu den Lagerstellen überwacht. Im Vergleich mit den üblichen Niveauewächtern im Kurbelgehäuse ist damit eine effektivere Schutzfunktion gewährleistet.

Content

- 1 Application
- 2 Technical features
- 3 Electrical connection
- 4 Mounting

1 Application

An adequate oil supply is very important for the operating life of a compressor. Lack of lubrication, e. g. due to oil shortage, can lead to serious damage of the drive gear.

The newly developed monitoring system OLC-K1 checks the oil supply of reciprocating compressors lubricated by an oil centrifuge. This system is recommended especially for plants with a widely extended pipe work, or for applications in which larger quantities of oil can migrate to the low pressure side (e.g. critical flow velocities at part load).

The oil supply of the compressor is monitored directly at the shaft intake to the bearings. A more effective protection function is guaranteed, compared to usual oil level monitoring devices in the crankcase.

Sommaire

- 1 Application
- 2 Caractéristiques techniques
- 3 Raccordement électrique
- 4 Montage

1 Application

Une alimentation d'huile suffisante est très importante pour la durée de vie d'un compresseur. Un défaut de lubrification par ex. par manque d'huile peut engendrer des dégâts importants sur le mécanisme d'entraînement.

Le dispositif de protection OLC-K1 développé nouvellement surveille l'alimentation d'huile des compresseurs avec lubrification centrifuge. Ce dispositif est recommandé particulièrement pour des systèmes avec un réseau de tuyauterie très ramifié ou pour des applications, où des grandes quantités d'huile peuvent migrer vers le côté basse pression (par ex. vitesses d'écoulement critiques en charge partielle).

L'alimentation d'huile du compresseur est surveillée directement au point d'injection vers les paliers. En comparaison avec des dispositifs de contrôle de niveau habituels dans le carter, une fonction de protection plus effective est ainsi garantie.

2 Technische Merkmale

Das OLC-K1 ist ein opto-elektronischer Ölsensor, der die Ölversorgung berührungslos mit infrarotem Licht überwacht. Es besteht aus zwei Teilen: einer Prisma-Einheit und einer opto-elektronischen Einheit (Abb. 1).

- Die Prisma-Einheit wird direkt im Bereich der Ölzufuhr zu den Lagerstellen in den Lagerdeckel eingeschraubt (Abb. 2).
- Die opto-elektronische Einheit steht nicht in direkter Verbindung mit dem Ölkreislauf. Sie wird in die Prisma-Einheit eingeschraubt und in die Steuerungslogik der Anlage integriert. Ein externes Steuergerät ist nicht erforderlich.

i Im Unterschied zum Schutzgerät INT265 ist das OLC-K1 zusätzlich mit Lauferkennung ausgestattet. Dadurch reduziert sich der Aufwand beim elektrischen Anschluss.

2 Technical features

The OLC-K1 is an opto-electronic oil sensor for contactless monitoring of the oil supply by means of infrared light. It consists of two parts: a prism unit and an opto-electronic unit (figure 1).

- The prism unit is screwed into the bearing cover directly at the oil supply areas for the bearings (figure 2).
- The opto-electronic unit is not in direct contact with the oil circuit. It is screwed into the prism unit and integrated into the control circuit of the plant. An external control module is not required.

i In contrast to the protection device INT265, the OLC-K1 is additionally equipped with operating recognition. Thus, the electrical connection is simplified.

2 Caractéristiques techniques

Le OLC-K1 est une sonde d'huile opto-électronique, qui surveille l'alimentation d'huile sans contact, par lumière infrarouge. Il se compose de deux pièces: une unité prisme et une unité opto-électronique (figure 1).

- L'unité prisme est vissée dans le couvercle de palier directement au point d'injection d'huile vers les paliers (figure 2).
- L'unité opto-électronique n'est pas en contact avec le circuit d'huile. Elle est vissée sur l'unité prisme et intégrée dans la logique de commande de l'installation. Un module de commande extérieur n'est pas nécessaire.

i A la différence du dispositif de protection INT265, le OLC-K1 est équipé en plus avec une reconnaissance de marche. Ainsi le raccordement électrique est simplifié.

Technische Daten OLC-K1	Technical data OLC-K1	Données techniques OLC-K1	
Anschluss-Spannung	Supply voltage	Tension d'alimentation	230 V AC ± 10% *
Netzfrequenz	Supply frequency	Fréquence du réseau	50 / 60 Hz
Relais-Ausgänge: Schaltspannung Schaltstrom Schaltleistung	Relay output: Switching voltage Switching current Switching capacity	Sorties de relais: Tension de commutation Intensité de commutation Puissance de commutation	max. 250 V AC max. 2.5 A max. 300 VA
Vorsicherung für Gerät und Schaltkontakte	Fusing for device and switch contacts	Fusible pour appareil et contacts de commutation	max. 4 A
maximal zulässiger Druck	Maximum allowable pressure	Pression maximale admissible	32 bar
Schutzart (montiert)	Enclosure class (mounted)	Classe de protection (monté)	IP54
Anschlusskabel	Connecting cable	Câble de raccordement	6 x AWG 20 (0.5 mm ²) L = 1 m ①
Kältemittel	Refrigerants	Fluides frigorigènes	HFCKW, (H)FCKW HFC, (H)CFC ②
zulässige Umgebungstemperatur	Allowable ambient temperature	Température ambiante admissible	-30 .. +60°C
Gewicht	Weight	Poids	160 g

* andere Spannungen auf Anfrage, auch mit UL-Abnahme erhältlich

① Kabel farbkodiert

② nicht zugelassen für NH₃ und Kohlenwasserstoffe

* other voltages upon request, also available with UL approval

① Cables color coded

② not admitted to NH₃ and hydrocarbons

* d'autres types de tension sur demande, aussi avec contrôle UL

① Câbles avec code couleur

② non admis pour NH₃ et hydrocarbures

2.1 Funktion

Betriebsbereit

Mit dem Einschalten des Verdichters wird die Überwachung der Ölversorgung aktiv (Lauf-Erkennung).

Verriegeln

Wenn ein Ölman gel länger als die Verzögerungszeit andauert, wird der Verdichter abgeschaltet.

Verzögerungszeit:

- nach Verdichterstart 90 s
- im Betrieb 5 s

Das OLC-K1 öffnet dann den Ausgangskontakt und verriegelt elektronisch: Die Steuerspannung zum Verdichterschütz wird unterbrochen. Die rote LED auf der Stirnseite der opto-elektronischen Einheit (Abb. 1) und die Signallampe H2 leuchten.

Entriegeln

Das OLC-K1 kann über eine Reset-Taste manuell zurück gesetzt werden. Diese Reset-Taste (S3) muss im Schaltschrank montiert werden. (Anschluss siehe Prinzipschaltbild.)

- Vor dem Entriegeln Ursache für die Störung der Ölversorgung ermitteln und beseitigen.
- Spannungsversorgung (L/N) mindestens 5 Sekunden lang unterbrechen.

2.1 Function

Ready-to-operate

The oil supply monitoring is activated when the compressor is switched on (operating recognition).

Lock out

If the lack of oil takes longer than the delay time, the compressor is shut off.

Delay time:

- after compressor start 90 s
- in operation 5 s

The OLC-K1 then opens the output contact and locks out electronically: The control voltage to the compressor contactor is interrupted. The red LED at the face side of the opto-electronic unit lights up (figure 1) as well as the signal lamp H2.

Reset

The OLC-K1 can be manually reset by pressing the reset button. This reset button (S3) has to be mounted into the switch board. (Connection see schematic wiring diagram).

- Before resetting, determine the reason for the oil supply problem and fix it.
- Interrupt supply voltage (L/N) for at least 5 seconds.

2.1 Fonctionnement

Prêt à fonctionner

Avec la mise en marche du compresseur, le contrôle d'alimentation d'huile devient actif (reconnaissance de marche).

Verrouiller

Quand le manque d'huile dure plus longtemps que la temporisation, le compresseur est mis à l'arrêt.

Temporisation:

- après la mise en service 90 s
- en service 5 s

Le OLC-K1 ouvre alors le contact de sortie et verrouille électroniquement: la tension de commande du contacteur du compresseur est coupée. La LED rouge sur le côté frontal de l'unité opto-électronique s'allume (figure 1) et aussi la lampe H2.

Déverrouiller

Le OLC-K1 peut être remis manuellement en fonctionnement par la touche de reset. Cette touche (S3) devra être montée dans l'armoire électrique. (Raccordement voir schéma de principe.)

- Avant déverrouillage: déterminer la cause du défaut d'alimentation d'huile et y remédier.
- Interrompre la tension d'alimentation (L/N) durant 5 secondes minimum.

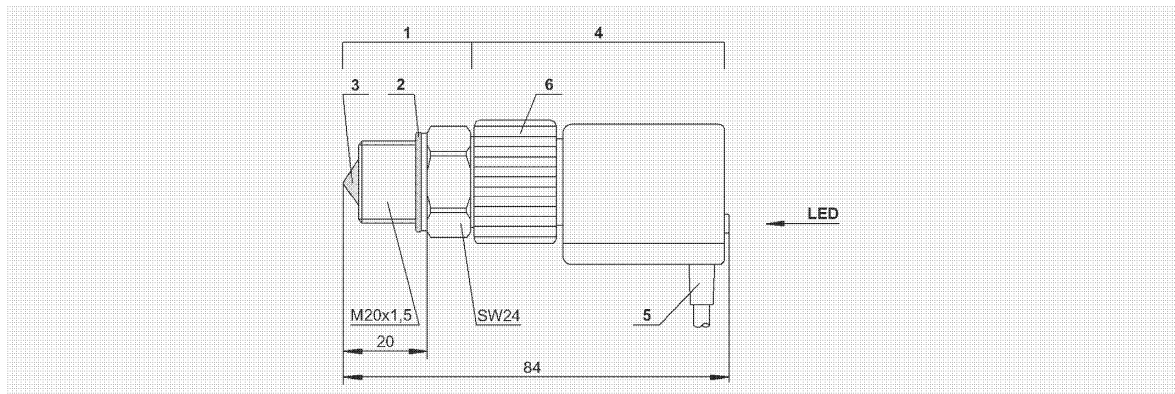

- 1 Prisma-Einheit
- 2 Kupfer-Dichtscheibe
- 3 Glas-Kegel
- 4 Opto-elektronische Einheit (360° drehbar)
- 5 Anschlusskabel
- 6 Schraubkappe

Abb. 1 Abmessungen und Aufbau

- 1 Prism unit
- 2 Copper sealing washer
- 3 Glass cone
- 4 Opto-electronic unit (360° revolving)
- 5 Connecting cable
- 6 Screwing cap

Fig. 1 Dimensions and design

- 1 Unité prisme
- 2 Rondelle d'étanchéité en cuivre
- 3 Cône en verre
- 4 Composant opto-électronique (mobile sur 360°)
- 5 Câble de raccordement
- 6 Bouchon fileté

Fig. 1 Dimensions et construction

3 Elektrischer Anschluss

OLC-K1 entsprechend Prinzipschaltbild anschließen. Reset-Tasten S2 und S3 im Schaltschrank montieren.

Das folgende Prinzipschaltbild gilt für Teilwicklungs-Anlauf. Bei Direktstart entfallen K2, K1T und Y1.

Legende

B1Steuereinheit
B2Steuereinheit des Leistungsreglers (Option)
F1Hauptsicherung
F2Verdichter-Sicherung
F3Steuersicherung
F5Hochdruckschalter
F6Niederdruckschalter
F12Sicherung der Ölsumpfheizung
F13Überstrom-Relais "Motor" PW1 (empfohlen)
F14Überstrom-Relais "Motor" PW2 (empfohlen)
H1Signallampe "Übertemperatur (Motor und Druckgas)" sowie "Störung der Ölversorgung"
H2Signallampe "Störung der Ölversorgung"
K1Schütz "1. Teilwicklung"
K2Schütz "2. Teilwicklung"
K1TZeitrelais "Teilwicklung"
K2TZeitrelais "Pausenzeit" 300 s
M1Verdichter
Q1Hauptschalter
R1-6PTC-Fühler in Motorwicklung
R7Druckgas-Temperaturfühler (Option)
R8Ölsumpfheizung (Option)
S1Steuerschalter
S2Entriegelung "Übertemperatur (Motor / Druckgas)"
S3Entriegelung "Ölmangel"
U1EMV-Entstörglied (bei Bedarf)
Y1Magnetventil "Anlaufentlastung" (Option)
Y2Magnetventil "Flüssigkeitsleitung"
Y3Magnetventil "Leistungsregelung" (Option)
SE-B1 / SE-B2Verdichter-Schutzgerät
OLC-K1Überwachung der Ölversorgung

3 Electrical connection

Connect OLC-K1 according to schematic wiring diagram. Mount reset buttons S2 and S3 into switch board.

The following schematic wiring diagram applies to part winding start. For direct start K2, K1T and Y1 can be omitted.

Legend

B1Control unit
B2Control unit of capacity regulator (option)
F1Main fuse
F2Compressor fuse
F3Control circuit fuse
F5High pressure cut out
F6Low pressure cut out
F12Fuse of crankcase heater
F13Thermal overload "motor" PW1 (recommended)
F14Thermal overload "motor" PW2 (recommended)
H1Signal lamp "over temperature (motor and discharge gas)" and "oil supply fault"
H2Signal lamp "oil supply fault"
K1Contactor "first PW"
K2Contactor "second PW"
K1TTime relay "part winding"
K2TTime relay "pause time" 300 s
M1Compressor
Q1Main switch
R1-6PTC sensors in motor windings
R7Discharge gas temperature sensor (option)
R8Crankcase heater (option)
S1Control switch
S2Fault reset "over temperature (motor / discharge gas)"
S3Fault reset "lack of oil"
U1EMC screening unit (if required)
Y1Solenoid valve "start unloading" (option)
Y2Solenoid valve "liquid line"
Y3Solenoid valve "capacity control" (option)
SE-B1 / SE-B2Compressor protection device
OLC-K1Oil supply monitoring

3 Raccordement électrique

Raccorder le OLC-K1 suivant le schéma de principe. Monter les touches de reset S2 et S3 dans l'armoire électrique.

Le schéma de principe s'applique au démarrage à bobinage partiel. En démarrage direct K2, K1T et Y1 sont laissés à côté.

Légende

B1Unité de commande
B2Unité de commande du régulateur de puissance (option)
F1Fusible principal
F2Fusible compresseur
F3Fusible protection de commande
F5Pressostat haute pression
F6Pressostat basse pression
F12Fusible de résistance de carter
F13Relais thermique de moteur PW1 (recommandé)
F14Relais thermique de moteur PW2 (recommandé)
H1Lampe "excès de température" (moteur et gaz de refoulement) et "défaut d'alimentation d'huile"
H2Lampe "défaut d'alimentation d'huile"
K1Contacteur "bobinage 1"
K2Contacteur "bobinage 2"
K1TRelais temporisé "bobinage partiel"
K2TRelais temporisé "pause" 300 s
M1Compresseur
Q1Interrupteur principal
R1-6Sondes PTC dans les bobinages du moteur
R7Sonde de température du gaz de refoulement (option)
R8Résistance de carter (option)
S1Commutateur de commande
S2Réarmement "excès de température" (moteur et gaz de refoulement)
S3Réarmement "manque d'huile"
U1Élément d'antiparasitage de CEM (si nécessaire)
Y1Vanne magnétique "démarrage à vide" (option)
Y2Vanne magnétique "conduite de liquide"
Y3Vanne magnétique "régulation de puissance" (option)
SE-B1 / SE-B2Dispositif de protection du compresseur
OLC-K1Contrôle d'alimentation d'huile

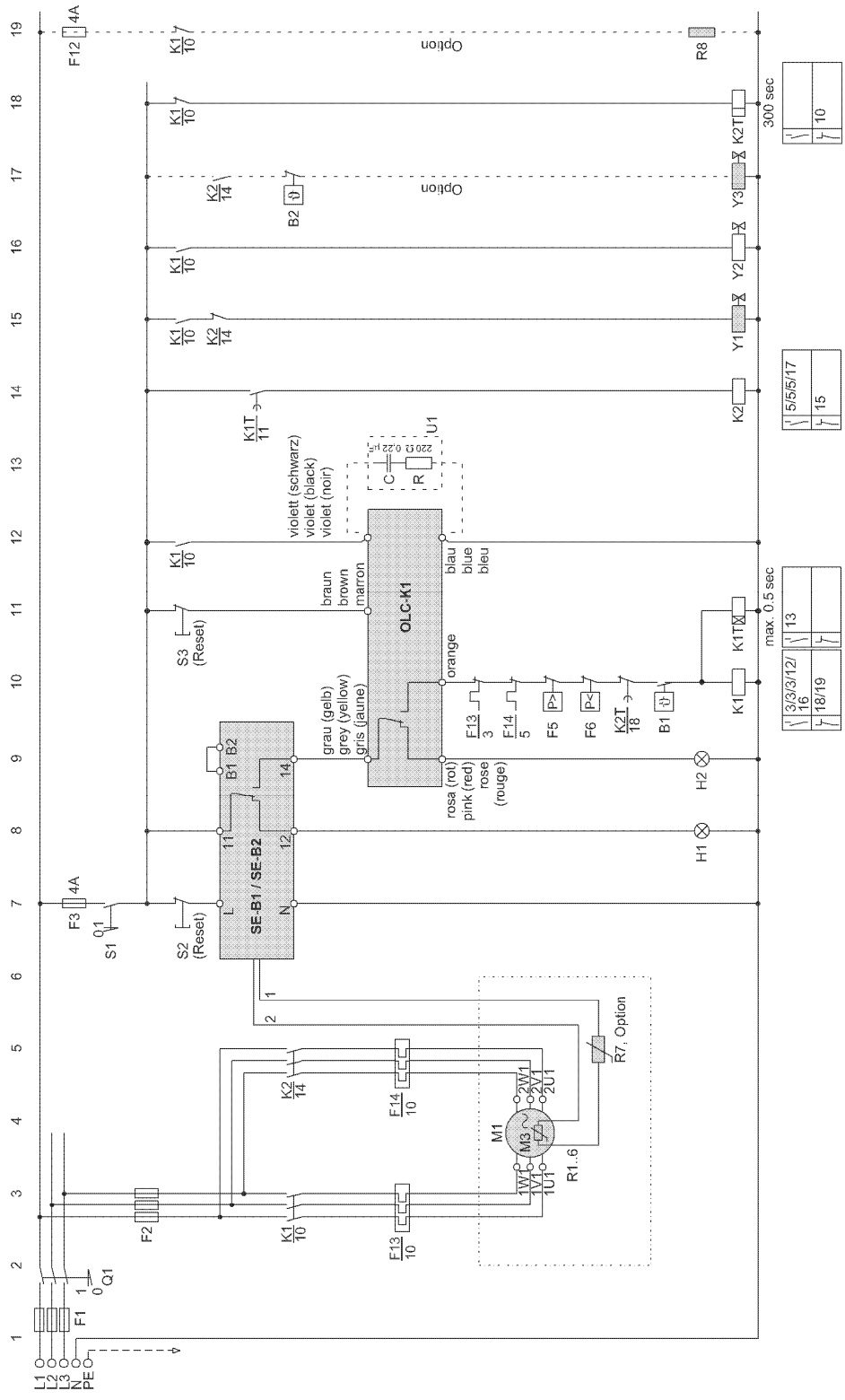

.....
 Details zum Anschluss siehe Innenseite Anschlusskasten.
 Details concerning connections see inside the terminal box.
 Détails sur le raccordement voir intérieur de la boîte de raccordement.

4 Montage

OLC-K1 vorzugsweise montieren, bevor der Verdichter in die Anlage eingebaut wird.

⚠ Warning!
Verdichter steht unter Druck!
Schwere Verletzungen möglich.
Verdichter auf drucklosen Zustand bringen!
Schutzbrille tragen!

- Verdichter kippen, indem er an der Unterseite des Lagerdeckels angehoben wird, damit das in der Öltasche des Lagerdeckels befindliche Öl nicht durch die Anschlussbohrung abfließen kann.
- Schraube (M20x1,5) am Lagerdeckel ausschrauben und Gewindeloch reinigen.
- Glaskegel der Prisma-Einheit innen und außen auf Sauberkeit prüfen und ggf. reinigen.
- Prisma-Einheit mit Metall-Dichtung in den Lagerdeckel einschrauben. Anzugsmoment ca. 75 Nm.

4 Mounting

Mount the OLC-K1 best before the compressor is installed.

⚠ Warning!
Compressor is under pressure!
Serious injuries are possible.
Release the pressure in the compressor!
Wear safety goggles!

- Tilt the compressor by lifting it at the bottom side of the bearing cover in order to keep the oil in the oil pocket of the bearing cover from draining through the connection bore.
- Remove the screw (M20x1,5) at the bearing cover and clean the threaded hole.
- Check if glass cone of prism unit is clean on inside and outside and clean if necessary.
- Fit the prism unit with metal gasket into the bearing cover. Tightening torque approximately 75 Nm.

4 Montage

Monter de préférence le OLC-K1, avant que le compresseur soit incorporé dans l'installation frigorifique.

⚠ Avertissement !
Compresseur est sous pression !
Des graves blessures sont possibles.
Retirer la pression sur le compresseur !
Porter des lunettes de protection !

- Basculer le compresseur en le soulevant côté couvercle de palier (l'agripper au bas du couvercle) afin que l'huile qui se trouve dans la poche de ce même couvercle ne s'écoule pas par l'alésage de raccordement.
- Dévisser la vis (M20x1,5) du couvercle de palier et nettoyer le trou taraudé.
- Vérifier la propreté du cône en verre de l'unité prisme à l'intérieur et à l'extérieur et le nettoyer, si nécessaire.
- Visser l'unité prisme avec joint métallique dans le couvercle de palier. Couple de serrage environ 75 Nm.



Abb. 2 OLC-K1 montieren

Fig. 2 Mounting of OLC-K1

Fig. 2 Monter le OLC-K1

- Opto-elektronische Einheit sorgfältig in die Prisma-Einheit bis zum Anschlag einschieben und Schraubkappe von Hand fest anziehen.

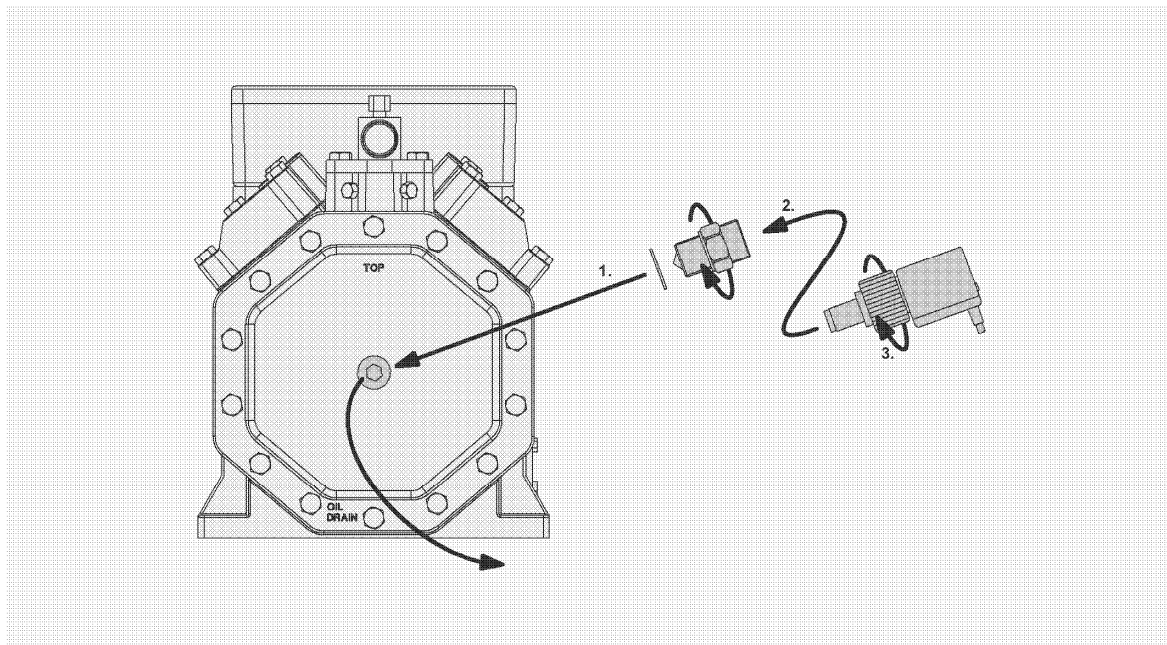
! Achtung!
Ausfall des Schutzgeräts möglich!
Unmittelbar vor dem Einschrauben der opto-elektronischen Einheit sicherstellen, dass die Prisma-Einheit trocken ist!
Kondenswasser sorgfältig entfernen!

! Achtung!
Gefahr von Verdichterausfall!
Zerstörung des Schutzgeräts durch eintretende Feuchtigkeit möglich!
Sicherstellen, dass der Kabelanschluss immer nach unten weist!

- Opto-elektronische Einheit keinesfalls demontieren!

- Slide the opto-electronic unit carefully into the prism to the stop and firmly tighten the screwing cap manually.

! Attention!
Possible failure of protection device!
Immediately before screwing in the opto-electronic unit, ensure that the prism is dry!
Remove condensing water carefully!

! Attention!
Danger of compressor breakdown!
Moisture ingress may destroy the protection device!
Ensure that the cable connection always points downwards!

- In no case dismount the opto-electronic unit!

- Glisser l'unité opto-électronique soigneusement dans l'unité prisme jusqu'à la butée et serrer fermement le bouchon fileté, à la main.

! Attention !
Défaillance du dispositif de protection possible !
Immédiatement avant de serrer la vis de l'unité opto-électronique, il faut garantir que l'unité prisme est sèche.
Enlever soigneusement l'eau condensation !

! Attention !
Danger de défaillance du compresseur !
Destruction du dispositif de protection possible par introduction d'humidité !
Garantir que le raccordement de câble est toujours dirigé vers le bas.

- En aucun cas, démonter l'unité opto-électronique !

Oil Pressure Monitoring

Types

Semi-hermetic and open drive BITZER reciprocating compressors with integrated oil pump Content

1 General

An adequate oil supply is very important for the operating life of a compressor. Lack of lubrication e. g. due to oil shortage can lead to serious damage of bearings and sliding surfaces. BITZER offers two systems for monitoring the oil pressure of pump lubricated reciprocating compressors: in addition to the externally mounted differential oil pressure switches also an incorporated sensor Delta-PII is available. It is directly screwed into the pump housing of the compressor (bearing cover). The main advantage is that tube connections, with the danger of breakage, are not used between compressor and differential oil pressure switch. Thus the mounting effort is reduced and the safety in view of leakages is increased at the same time.

2 Differential oil pressure switch Delta-PII

2.1 Technical features

- The differential oil pressure switch Delta-PII consists of two parts: a sensor unit and an electronic unit (fig. 1).
- The sensor unit is screwed directly into the pump housing of the compressor (bearing cover, fig. 2). It contains a switching element which is connected by channels with the suction and discharge pressure of the oil pump. Therefore external tubes and flare connections are omitted.
- The electronic unit is not in direct contact with the oil circuit. It is screwed into the sensor unit. Thus, the mounting and dismantling is possible without intervention into the refrigeration circuit. An external control module is not required. • The red LED at front end of the electronic unit (fig. 1) signals the operating condition of Delta-PII while compressor is running.

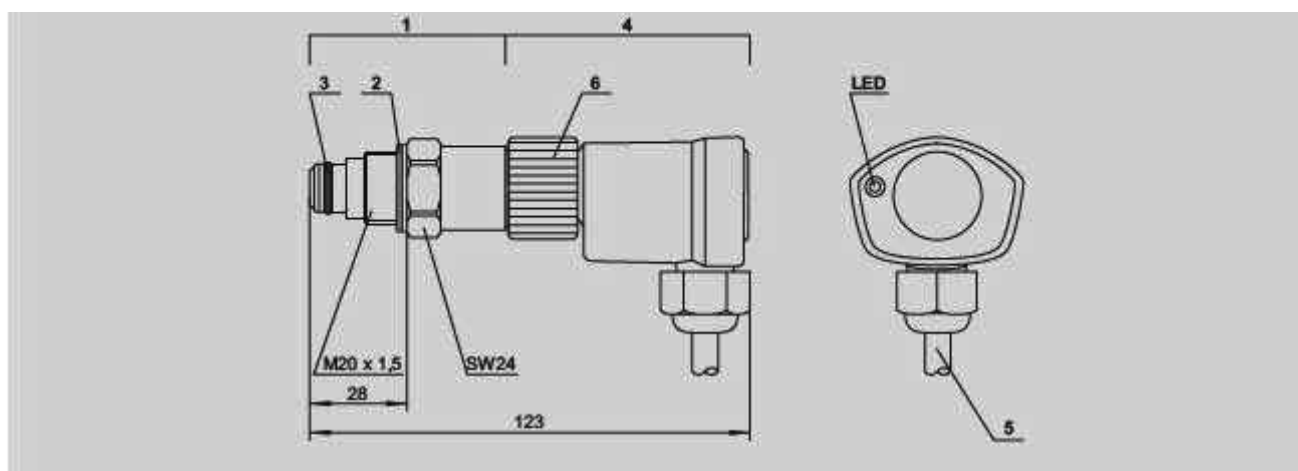

1	Sensor-Einheit
2	Metall-Dichtscheibe
3	O-Ring
4	Elektronische Einheit (360° drehbar)
5	Anschlusskabel
6	Schraubkappe

1	Sensor unit
2	Metal sealing washer
3	O-ring
4	Electronic unit (360° revolving)
5	Connecting cable
6	Screwing cap

1	Unité de sonde
2	Rondelle d'étanchéité métallique
3	Joint annulaire
4	Unité électronique (mobile sur 360°)
5	Câble de raccordement
6	Bouchon fileté

Abb. 1 Abmessungen und Aufbau des Delta-PII

Fig. 1 Dimensions and design of the Delta-PII

Fig. 1 Dimensions et construction de Delta-PII

The Delta-PII is optionally available as a pure switching device (with REED contact) – e. g. for PLC control. Time delay must then be integrated into the control logic.

2.2 Technical data

- Operating voltage: 115 .. 230 V AC +10% / -15%, 50/60 Hz also available with UL approval
- Power consumption: 3 VA
- Relay output: Switch voltage 250 V ~ Switching current max. 2.5 A Switching capacity 300 VA ind.
- Connecting cables: 6 x AWG18 (0,75 mm²) L = 1 m color coded
- Differential cut-out pressure: 0,65 bar
- Time delay with insufficient differential oil pressure: 90 s ± 5 s
- Lock out: electrical
- Admissible ambient temperature: -30°C .. +70°C
- Fuse for protection device and switch contacts: max. 6 A
- Enclosure class: IP54 when electronic unit is mounted and connecting cable points downwards
- Refrigerants: HFC, (H)CFC not admitted to NH3
- Weight: 200 g

2.3 Function Compressor start

The oil pressure monitoring is activated when supply voltage is applied via an auxiliary contact of the motor contactor K1 (operating recognition, see also schematic wiring diagram). The LED at the front end of the electronic unit immediately signals an insufficient differential oil pressure.

Operation

Once the preset value has been reached, this LED extinguishes. The output contact remains closed if the differential oil pressure reaches or exceeds the preset value.

Differential oil pressure below preset value

If the differential oil pressure remains or drops below the preset value for longer than the time delay (approx. 90 s), the output contact opens. The Delta-PII locks out and shuts off the compressor. The signal lamp H2 and the LED at the protection device both stay on until Delta-PII has been reset. Shorter times of insufficient oil pressure are also recognised by the internal microprocessor. They also lead to a compressor shut-off after a correspondingly extended time delay (time integration).

Manual reset

Interrupt power supply (L/N) for at least 5 seconds (reset button S3, see schematic wiring diagram).

Fault of Delta-PII

In case the supply voltage is too low or if the electronic unit is not completely mounted, the Delta-PII locks out. The LED at the front end of the electronic unit is flashing.

LED indications

- LED is on: lack of oil The signal lamp H2 is also on.
- LED is flashing: fault of Delta-PII
- LED is off: sufficient oil supply

2.4 Mounting

Warning!

Compressor is under pressure! Serious injuries are possible. Release the pressure in the compressor! Wear safety goggles!

- Close the shut-off valves at the compressor and release the pressure in the compressor.
- Unscrew the plug (or mounted pressure sensor) at the bearing cover and clean the threaded hole.
- Fit the sensor unit with o-ring and metal sealing washer into the bearing cover. Mount the o-ring very carefully, do not damage it! Tightening torque approx. 75 Nm.
- Slide the electronic unit to the stop and firmly tighten the screwing cap manually. This unit is freely revolving. Position connecting cable facing downwards.

Attention!

Moisture ingress may destroy the protection device! Ensure that the connecting cable always points downwards!

- Connect cables according to schematic wiring diagram (see chapter 2.5).



Abb. 2 Öldifferenzdruck-Schalter Delta-PII montieren.

Fig. 2 Mounting the differential oil pressure switch Delta-PII.

Fig. 2 Monter le pressostat différentiel d'huile Delta-PII.

2.5 Electrical connection

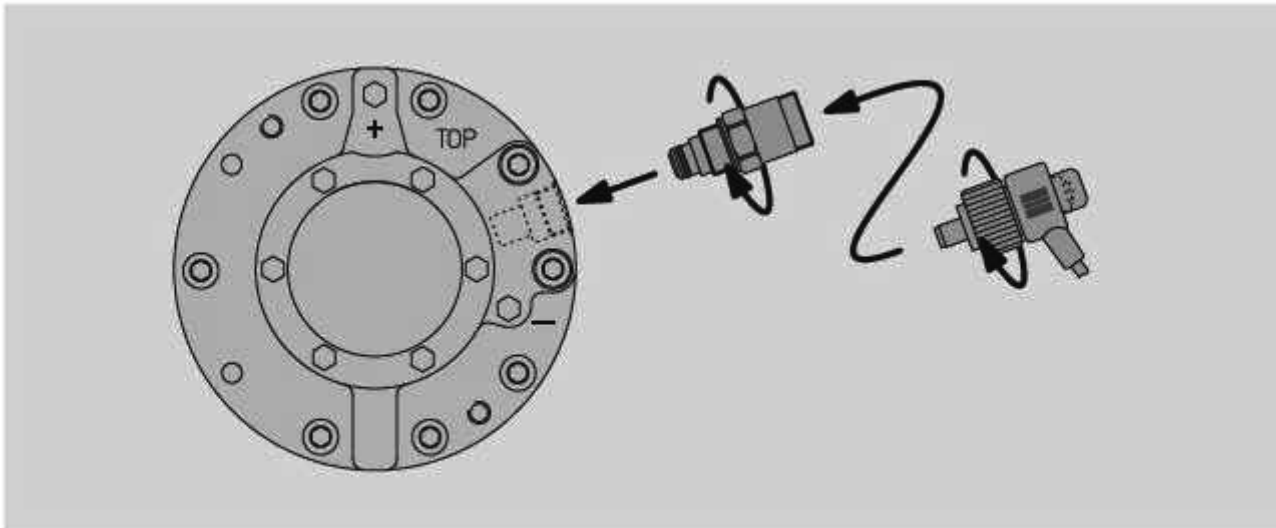
Connect Delta-PII according to schematic wiring diagram. Mount reset buttons S2 and S3 into switch board. The following schematic wiring diagram applies to part winding start. For direct start K2, K1T and Y1 can be omitted.

Legend

- B1Control unit
- B2Control unit of capacity regulator (option)

- F1Main fuse
- F2Compressor fuse
- F3Control circuit fuse
- F5High pressure cut out
- F6Low pressure cut out
- F12Fuse of crankcase heater
- F13Thermal overload "motor" PW1 (recommended)
- F14Thermal overload "motor" PW2 (recommended)
- H1Signal lamp "over temperature (motor and discharge gas)" and "oil supply fault"
- H2Signal lamp "oil supply fault"
- K1Contactor "first PW"
- K2Contactor "second PW"
- K1TTime relay "part winding"
- K2TTime relay "pause time" 300 s
- M1.....Compressor
- Q1.....Main switch
- R1-6 ..PTC sensors in motor windings
- R7Discharge gas temperature sensor (option)
- R8Crankcase heater (option)
- S1Control switch
- S2Fault reset "over temperature (motor / discharge gas)"
- S3Fault reset "lack of oil"
- Y1Solenoid valve "start unloading" (option)
- Y2Solenoid valve "liquid line" (option)
- Y3Solenoid valve "capacity control" (option)
- SE-B1 / SE-B2Compressor protection device
- Delta-PIIDifferential oil pressure switch

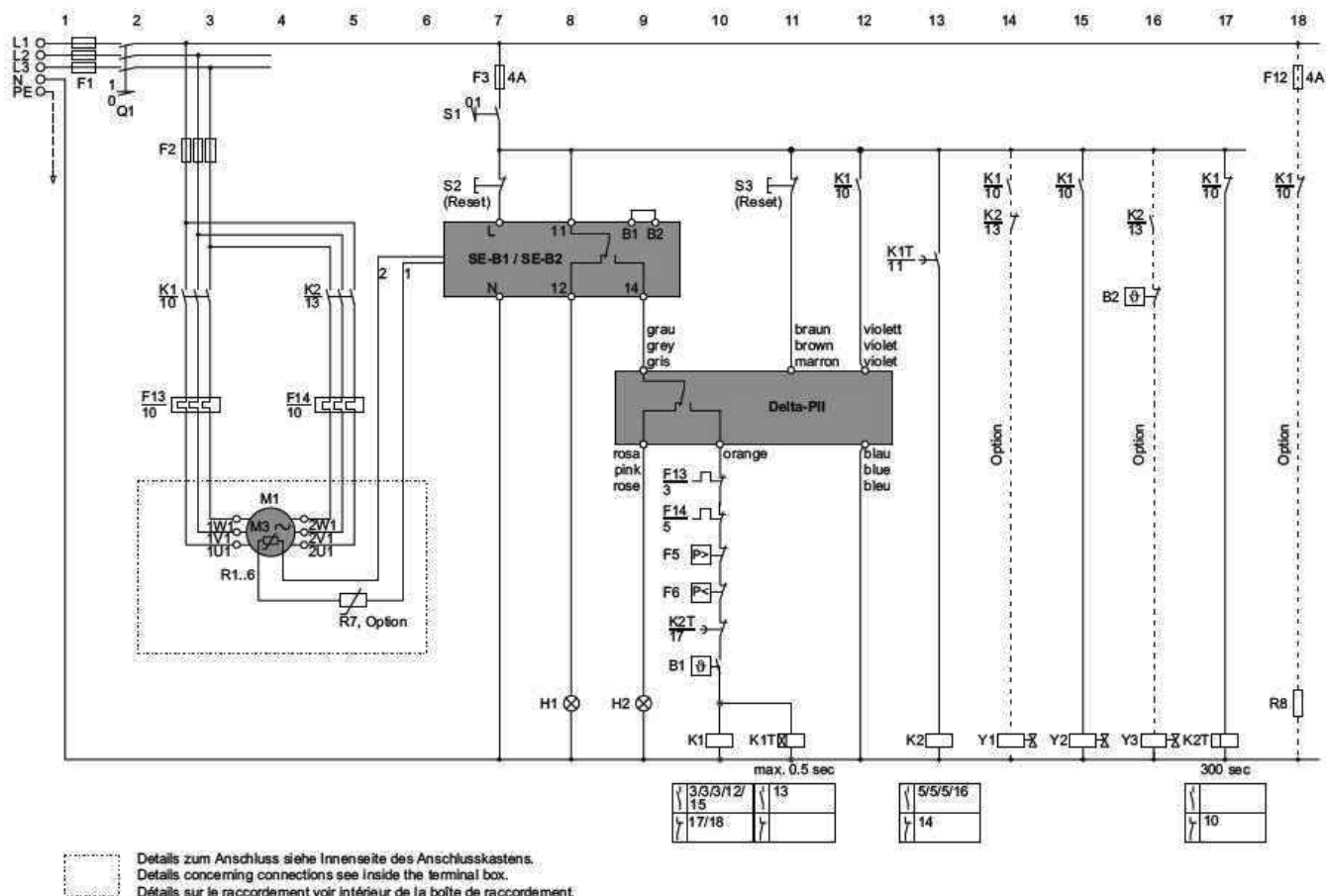

2.6 Function test

Check when the compressor is shut off. Remove the motor fuses and – if refrigerant is already charged – cut the power supply to the liquid solenoid valve(s). Switch on the control voltage. The compressor contactor (K1) closes and thus activating the differential oil pressure monitoring. With correct function the LED will be lit about 90 s. Afterwards the output contact and the compressor contactor open. The signal lamp H2 lights up additionally.

Appendix 4 : Copeland operating instructions for oil pressure monitoring "OPS1"

Application

Monitoring the oil differential pressures in refrigeration compressors. OPS1 consists of two parts: a pressure sensor and an electronic switch. It is easy to apply and due to the pre-assembled sensor environmentally friendly, the risks of refrigerant leakage are minimized.

The pressure sensor of the oil differential switch is directly screwed into the pump housing of the compressor. Internal channels link the switch to the suction and discharge ports of the oil pump. No capillary connections are necessary. The electronic switch can be fitted or removed without opening the refrigeration circuit.

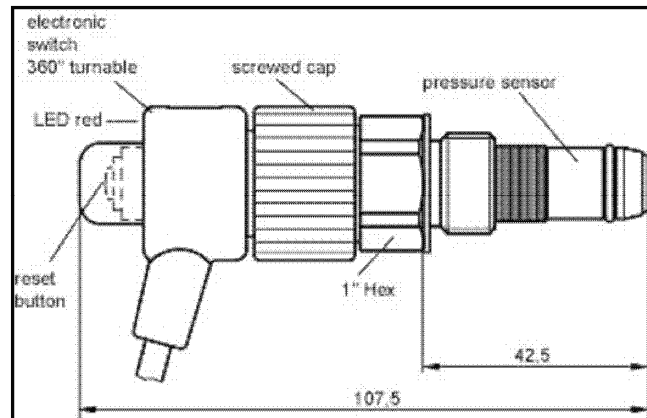

Functional description:

The differential pressure monitor is activated when the supply voltage is applied via an auxiliary contact of the motor contactor K1. A red LED signals insufficient differential oil pressure immediately. Once the pre-set value has been reached, the LED is extinguished. The output contact remains closed when the set value is reached or exceeded. If the oil differential pressure remains or drops below the set value for longer than the time delay time, the output contact opens and locks out mechanically. Depressing the reset button can reactivate the switch. Shorter periods of insufficient differential pressure are also recognised by the internal microprocessor circuitry and lead to a trip and lockout after correspondingly extended delay time (integration).

 Trained electrical personnel must connect the unit. All valid standards for connecting electrical and refrigeration equipment must be observed. Limit values for the supply voltage of the unit may not be exceeded. The oil differential switch needs no maintenance.

Technical data:	
Supply voltage	AC 50/60 Hz 230V +/- 10% 10VA
Ambient temperature range	-30.....+60°C
Time delay	120 s
Cut-in pressure (fixed)	0,95 bar +/- 0,15 bar
Cut-out pressure (fixed)	0,63 bar +/- 0,15 bar
Switching capacity	AC 250 V, max. 2,5A, 720 VA ind.
Refrigerant compatibility	yes (brass)
Protection class according EN 60529	IP54
Reset	manual
Connection cable	4xAWG20 (0,5 mm ²), L=1m colour coded cores
Weight	ca. 200 g

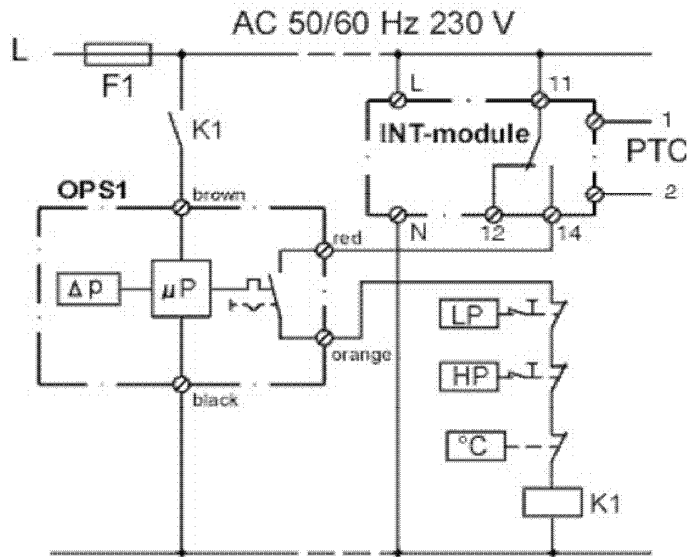

Wiring diagram OPS 1 with aux. relay KD
(alarm-integration)

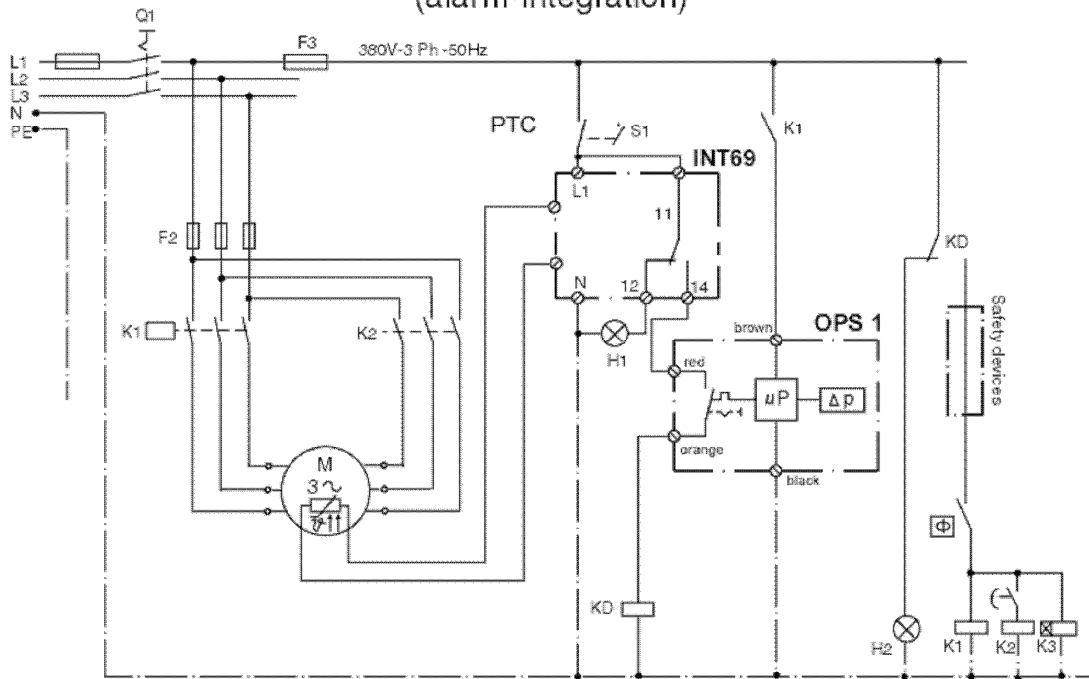

Appendix 5 : Operating instructions for oil management system series "INT 280 – 230V"

KRIWAN

INT280® Oil level regulator

INT280®

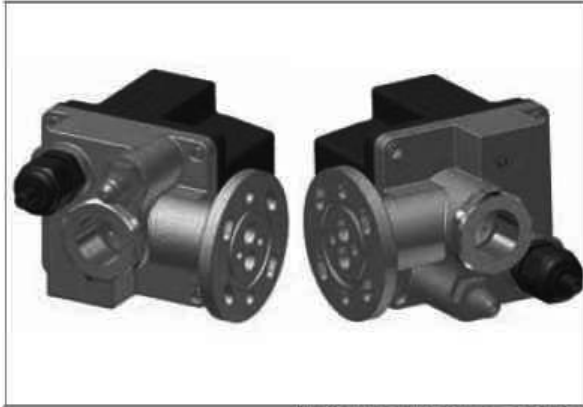

INT280 in the two mounting positions

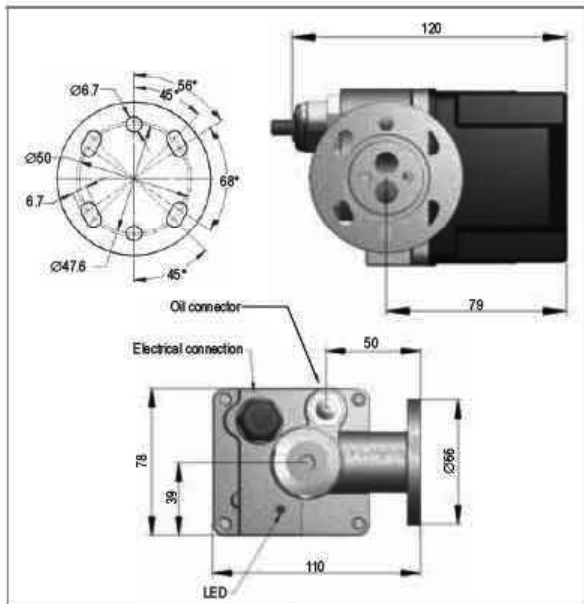

Dimensions in mm

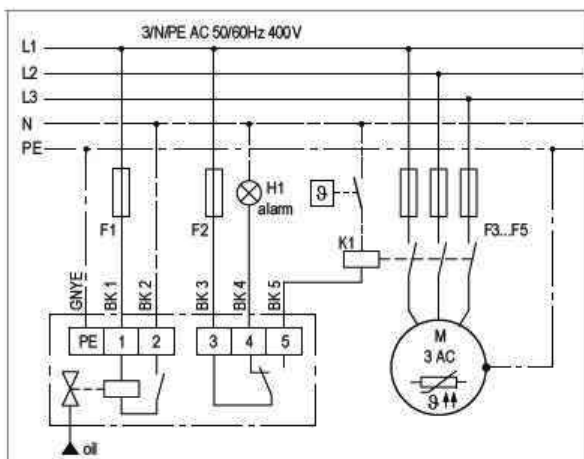

Wiring diagram (suggestion)

Application

The INT280 monitors and controls the oil level in the refrigerant compressors. In particular, the problem of bad oil distribution in multi-compressor packs is solved, thanks to active oil supply from a shared oil reservoir. The oil level regulator keeps the oil level at half the height of the sight glass.

Functional description

If the optical monitoring unit detects that the oil level is low, the integrated oil supply solenoid valve is activated by the electronics. Via the solenoid valve, oil is cyclically injected into the compressor crankcase. The INT280 generates an alarm signal and activates the relay output if the oil level is still too low after a defined period of time. During the "oil deficiency" alarm status, the electronics of the INT280 continues to operate the solenoid valve, in order to inject oil into the crankcase. The alarm status is automatically reset if the oil level is at half the height of the sight glass.

LED status display

Level OK	Green is continuously lit
Filling	Green flashes
Oil level too low	Red is continuously lit
Internal error	Red flashes

Installation instructions

The user has to ensure that the flange is properly tight. The electrical connection needs to be carried out according to the wiring diagram.

⚠ The unit must be connected by trained electrical personnel. All valid European and national standards for connecting electrical equipment must be observed.

Technical specifications

Supply voltage	AC 24V 50/60Hz ±10%, 15VA AC 115V 50/60Hz ±10%, 15VA AC 230V 50/60Hz ±10%, 15VA
Permitted ambient temperature	-30...+60°C
Medium temperature	-30...+100°C
Operating pressure	-1...46bar
Differential pressure:	1...25bar (across valve)
Relay	AC 240V, 2.5A, C300
Mechanical service life	Approx. 10 ⁶ switching cycles
Protection class acc. to EN 60529	IP65
Connecting cable	6xAWG18 (0.75mm ²), length 1m
Housing material	Aluminium PA66/PA6, glass-fibre-reinforced
Flange connection	3- /4- hole flange
Oil connection	7/16"-20 UNF
Permitted oils	Standard mineral and ester oil, without additives
Permitted refrigerants	All non-corrosive standard refrigerants
Dimensions	Refer to dimensions
Weight	Approx. 950g

Order data

AC 24V	31 S 381
AC 115V	41 S 381
AC 230V	52 S 381

KRIWAN

INT275 L[®]

Level monitoring

INT275 L[®]



INT275 L

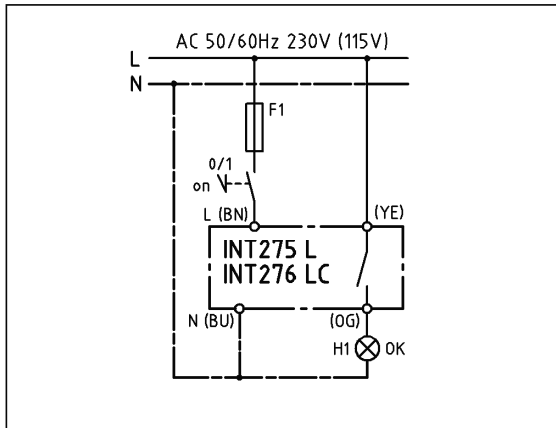

Connection diagram

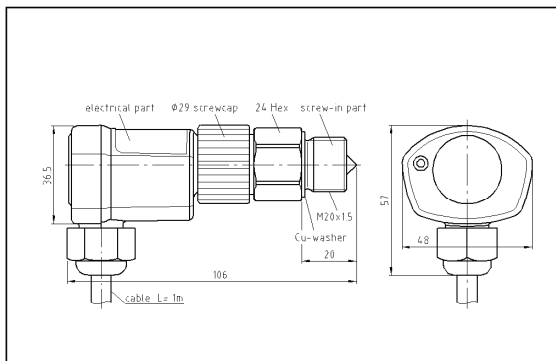

Dimensions in mm



The unit must be connected by trained electrical personnel. All valid standards for connecting elec-

trical equipment must be observed. Limit values for the supply voltage of the unit may not be exceeded.

Application:

The optical sensor INT275 L is developed for contactless level monitoring of liquids. A screw-in part mounted at the required location and a removable electrical part perform this function. The electrical part can be fitted or removed without opening the liquid tank. When the supply voltage is applied, the relay switches on after about 3s.

On absence of liquid or when a fault occurs the relay trips after a delay. When liquid is present or the fault disappears, the relay pulls in after a delay. The potential free normally open contact can be directly wired in a control circuit without an additional auxiliary relay. An integrated self-monitoring circuit ensures high reliability. A mounting check eliminates wrong installation or manipulation.

Installation instruction:

Mounting:

The installer must ensure seal tightness for the specific application. The maximum tightening torque is approx. 75Nm. Clean the inside of the screw-in part as well as the prism. Fit the electrical part in the screw-in part and tighten

the coupling ring (torque approx. 10Nm). Pay attention to the position of the lead (cable exit downwards). Complete the electrical wiring in accordance with the attached circuit suggestions. After filling the tank, check the tightness of all joints.

Technical data screw-in part

Ambient temperature range	-30...+60°C
Max. temperature at prism	+80°C
Test pressure	32bar
Housing	VA 1.4510 or 1.4305
Mounting	M20x1.5mm, wrench size 24 NPT1/2", wrench size 24
Weight	approx. 75g

Technical data electrical part

Supply voltage (52S...)	AC50/60Hz 230V ±10%
Supply voltage (41S...)	AC50/60Hz 115V ±10%
Ambient temperature range	-30...+60°C
Delays	
- Relay on after supply voltage on	3s±1s
Level monitoring active after	
Relay on	
Relay off (low level) after	5s±2s
Relay off (fault) after	5s±2s
Relay on (level high again) after	5s±2s
Relay on (fault disappears) after	5s±2s
Relay	AC250V, 2.5A, C300
Mechanical service life	approx. 10 ⁵ switching cycles
Housing	Ultramid A3XZG5
Protection class acc. to EN60529	IP54 when mounted
Mounting	coupling ring on screw-in part
Connecting cable	4xAWG18 (0.75mm ²) L=1m, colour-coded
Weight	approx. 80g

Ordering information

230V-Version: INT275 L Level monitoring	
Electrical Part	52S475S60
115V-Version: INT275 L Level monitoring	
Electrical Part	41S475S60
screw-in part M20x1.5mm	02K465
screw-in part NPT1/2"	02K460S22

Subject to technical modifications without notice

FRIGA-BOHN®



LFB France

42 rue Roger Salengro - BP 205
69741 GENAS CEDEX - FRANCE

Tél. : +33 4 72 47 13 00 - Fax : +33 4 72 47 13 96
www.frigabohn.com

Friga-Bohn se réserve le droit d'apporter toute modification sans préavis.
Friga-Bohn reserves itself the right to make changes at any time without preliminary notice.
Friga-Bohn Angaben und Abbildungen unverbindlich. Änderungen vorbehalten.
Friga-Bohn se reserva el derecho de aportar cualquier modificación sin preaviso
Friga-Bohn zastrzega sobie prawo do wprowadzania zmian bez uprzedzenia

MULTI HAVANE

Condensing units

N° IN0010600-H

04.2025