

MEGA

Condensing Units

Installation instructions

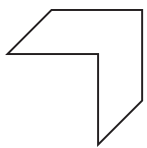

Cooling solutions, delivered with care.

www.frigabohn.com

Dimensional characteristics

Standard without casing

➤ **MEGA 1 fan – Ø = 500 mm**

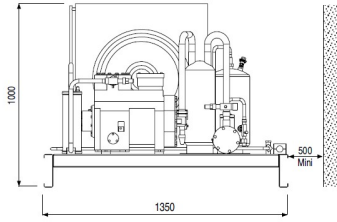

L 1350 x W 850 x H 1000

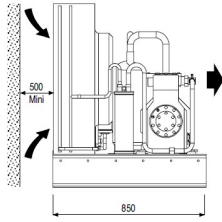

➤ **MEGA 2 fans – Ø = 500 mm**

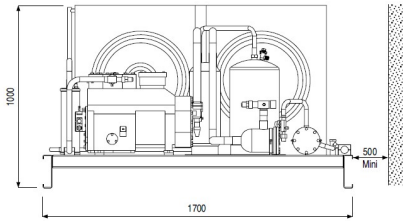

L 1700 x W 950 x H 1000

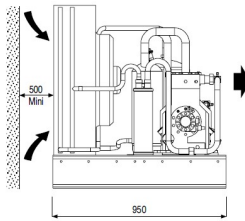

➤ **MEGA 2 fans – Ø = 630 mm**

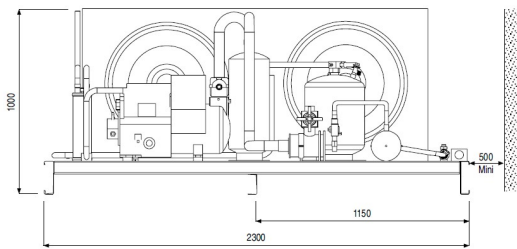

L 2300 x W 1200 x H 1000

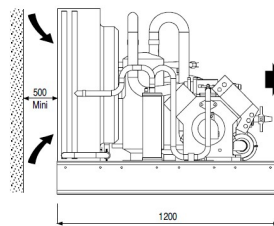

➤ **MEGA 4 fans – Ø = 630 mm**

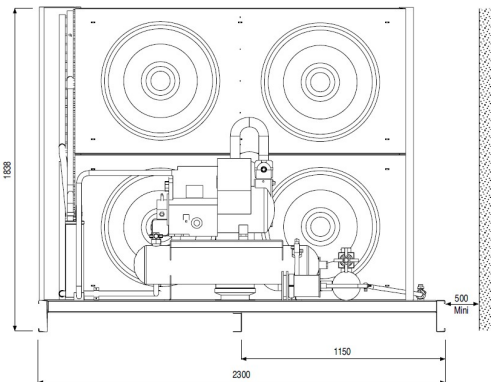

L 2300 x W 1200 x H 1838

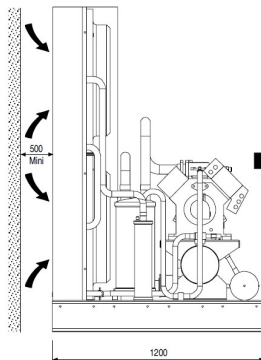

With casing option

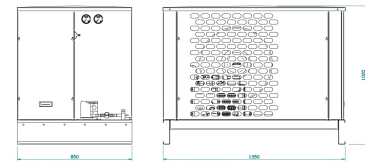

L 1350 x W 850 x H 1020

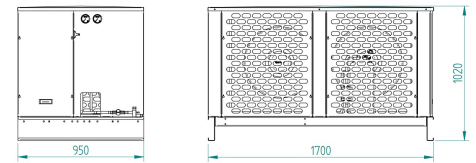

L 1700 x W 950 x H 1020

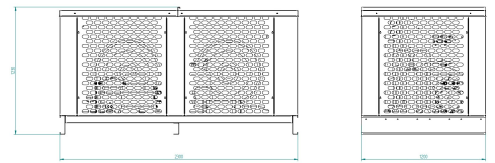

L 2300 x W 1200 x H 1230

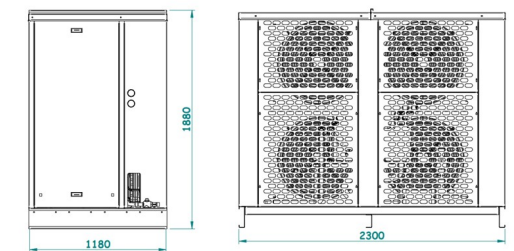

L 2300 x W 1200 x H 1880

MEDIUM TEMP MODELS			Compressor type	Fans (Nb x Ø)	Liquid (L) receiver (L)	Suction (inches)	Liquid (inches)	Weight without casing (kg)	Weight with casing (kg)
MEGA	P	80A	H	2x500	11	1"3/8	5/8"	216	301
	P	85A	H	2x500	11	1"3/8	5/8"	227	312
	P	100A	H	2x500	15	1"3/8	7/8"	239	324
MEGA	P	80A	SH	1x500	11	1"3/8	5/8"	264	339
	P	85A	SH	2x500	11	1"3/8	5/8"	313	398
	P	100A	SH	2x500	15	1"3/8	7/8"	337	422
	P	170A	SH	2x500	24	1"5/8	7/8"	362	447
	P	200A	SH	2x630	30	1"5/8	7/8"	418	538
	P	250A	SH	2x630	30	2"1/8	7/8"	470	590
	P	300A	SH	4x630	40	2"1/8	7/8"	558	718
	P	350A	SH	4x630	40	2"1/8	7/8"	597	757
	P	400A	SH	4x630	40	2"1/8	1"1/8	600	760
	P	500A	SH	4x630	40	2"1/8	1"1/8	623	783
MEGA	P	80A	Sc	1x500	11	1"3/8	5/8"	219	294
	P	85A	Sc	2x500	11	1"3/8	5/8"	259	344
	P	100A	Sc	2x500	15	1"3/8	7/8"	272	357
	P	170A	Sc	2x500	24	1"5/8	7/8"	277	362

MEDIUM TEMP MODELS			Compressor type	Fans (Nb x Ø)	Liquid (L) receiver (L)	Suction (inches)	Liquid (inches)	Weight without casing (kg)	Weight with casing (kg)
MEGA	P	80AS	H	2x500	11	1"3/8	5/8"	225	310
	P	85AS	H	2x500	11	1"3/8	5/8"	235	320
	P	100AS	H	2x500	15	1"3/8	7/8"	353	438
MEGA	P	80AS	SH	2x500	11	1"3/8	5/8"	294	379
	P	85AS	SH	2x500	11	1"3/8	5/8"	322	407
	P	100AS	SH	2x500	15	1"3/8	7/8"	419	504
	P	170AS	SH	2x630	30	1"5/8	7/8"	415	535
	P	200AS	SH	4x630	40	1"5/8	7/8"	501	661
	P	250AS	SH	4x630	40	2"1/8	7/8"	553	713
	P	300AS	SH	4x630	40	2"1/8	7/8"	578	738
	P	350AS	SH	4x630	40	2"1/8	7/8"	617	777
	P	400AS	SH	4x630	40	2"1/8	1"1/8	620	780
MEGA	P	80AS	Sc	2x500	11	1"3/8	5/8"	249	334
	P	85AS	Sc	2x500	11	1"3/8	5/8"	259	344
	P	100AS	Sc	2x500	15	1"3/8	7/8"	280	365

LOW TEMP MODELS			Compressor type	Fans (Nb x Ø)	Liquid (L) receiver (L)	Suction (inches)	Liquid (inches)	Weight without casing (kg)	Weight with casing (kg)
MEGA	N	55A	H	1x500	11	1"1/8	1/2"	175	238
	N	85A	H	1x500	11	1"3/8	1/2"	186	249
MEGA	N	55A	SH	1x500	11	1"1/8	1/2"	269	332
	N	85A	SH	1x500	11	1"3/8	1/2"	277	340
	N	105A	SH	2x500	15	1"3/8	5/8"	326	400
	N	155A	SH	2x500	15	1"5/8	5/8"	359	433
	N	205A	SH	2x500	24	2"1/8	7/8"	385	459
	N	255A	SH	2x500	24	2"1/8	7/8"	417	491
	N	305A	SH	2x630	30	2"1/8	7/8"	497	727
	N	405A	SH	2x630	40	2"1/8	7/8"	508	738
MEGA	N	55A	Sc	1x500	11	1"1/8	1/2"	212	275
	N	85A	Sc	1x500	11	1"3/8	1/2"	220	273
	N	105A	Sc	2x500	15	1"3/8	5/8"	253	327
	N	155A	Sc	2x500	15	1"5/8	5/8"	293	367

LOW TEMP MODELS			Compressor type	Fans (Nb x Ø)	Liquid (L) receiver (L)	Suction (inches)	Liquid (inches)	Weight without casing (kg)	Weight with casing (kg)
MEGA	N	55AS	H	2x500	11	1"3/8	1/2"	209	283
	N	85AS	H	2x500	11	1"3/8	1/2"	225	299
MEGA	N	55AS	SH	1x500	11	1"1/8	1/2"	273	336
	N	85AS	SH	2x500	11	1"3/8	1/2"	311	385
	N	105AS	SH	2x500	15	1"3/8	5/8"	335	409
	N	155AS	SH	2x500	15	1"5/8	5/8"	367	441
	N	205AS	SH	2x500	24	2"1/8	7/8"	385	459
	N	255AS	SH	2x630	30	2"1/8	7/8"	489	719
	N	305AS	SH	2x630	30	2"1/8	7/8"	497	727
	N	405AS	SH	4x630	40	2"1/8	7/8"	591	881
MEGA	N	55AS	Sc	1x500	11	1"1/8	1/2"	216	279
	N	85AS	Sc	2x500	11	1"3/8	1/2"	250	324
	N	105AS	Sc	2x500	15	1"3/8	5/8"	272	346
	N	155AS	Sc	2x500	15	1"5/8	5/8"	303	377

Technical data

Standard models

-10°C / 32°C		MEGA	P80A	P85A	P100A	P170A	P200A	P250A	P300A	P350A	P400A	P500A
Input power [H]	(kW)	7,95	9,63	12,19	-	-	-	-	-	-	-	-
Max. input amperage [H]	(A)	18,1	22,1	28,1	-	-	-	-	-	-	-	-
Input power [SH]	(kW)	5,65	8,15	9,4	12,76	15,9	20,18	26,83	31,74	38,27	43,41	
Max. input amperage [SH]	(A)	14	19,6	22,6	31,1	39,3	48,3	65,6	77,1	96,6	115,6	
Input power [Sc]	(kW)	7,07	9,09	11,78	14,15	-	-	-	-	-	-	-
Max. input amperage [Sc]	(A)	16,4	23,8	27,2	32	-	-	-	-	-	-	-
Rotation speed	(rpm)	1500	1500	1500	1500	1500	1500	1500	1500	1500	1500	1500
-35°C / 32°C		MEGA	N55A	N85A	N105A	N155A	N205A	N255A	N305A	N405A		
Input power [H]	(kW)	5,4	6,59	-	-	-	-	-	-	-		
Max. input amperage [H]	(A)	23	28	-	-	-	-	-	-	-		
Input power absorbée [SH]	(kW)	4,42	5,14	7,31	9,91	11,78	14,38	19,95	22,18			
Max. input amperage [SH]	(A)	13	15	21,6	33,1	35,1	47,1	61,8	84,8			
Input power [Sc]	(kW)	5,18	7,07	8,78	10,26	-	-	-	-			
Max. input amperage [Sc]	(A)	17,1	23,3	27,2	32,7	-	-	-	-			
Rotation speed	(rpm)	1500	1500	1500	1500	1500	1500	1500	1500	1500		

Capacity with 10K superheat and 3K subcooling

Models with oversized condenser

-10°C / 42°C		MEGA	P80AS	P85AS	P100AS	P170AS	P200AS	P250AS	P300AS	P350AS	P400AS
Input power [H]	(kW)	8,25	10,11	12,89	-	-	-	-	-	-	-
Max. input amperage [H]	(A)	18,1	22,1	28,1	-	-	-	-	-	-	-
Input power [SH]	(kW)	6,52	8,66	10,07	15,91	20,3	24,58	28,34	33,65	40,4	
Max. input amperage [SH]	(A)	15,1	19,6	22,6	35,8	46,1	55,1	65,6	77,1	96,6	
Input power [Sc]	(kW)	8,43	10,48	13,37	-	-	-	-	-	-	-
Max. input amperage [Sc]	(A)	17,5	23,8	27,2	-	-	-	-	-	-	-
Rotation speed	(rpm)	1500	1500	1500	1500	1500	1500	1500	1500	1500	1500
-35°C / 42°C		MEGA	N55AS	N85AS	N105AS	N155AS	N205AS	N255AS	N305AS	N405AS	
Input power [H]	(kW)	5,97	7,1	-	-	-	-	-	-	-	
Max. input amperage [H]	(A)	24,1	29	-	-	-	-	-	-	-	
Input power [SH]	(kW)	4,46	5,76	7,51	10,09	11,73	17,28	20,37	26,27		
Max. input amperage [SH]	(A)	13	16,1	21,6	33,1	39,1	51,6	61,8	91,6		
Input power [Sc]	(kW)	5,82	8,57	9,83	11,82	-	-	-	-		
Max. input amperage [Sc]	(A)	17,1	24,4	27,2	32,7	-	-	-	-		
Rotation speed	(rpm)	1500	1500	1500	1500	1500	1500	1500	1500	1500	

Capacity with 10K superheat and 3K subcooling

Please refer to the associated commercial and/or software documentation for further details.

Appendix 2: Connection of electrical wires on self stripping terminal blocks

MODE OF OPERATION

- 1- Control that the heart of the copper wire appears at insulation level.
If not, crop the end of the wire.

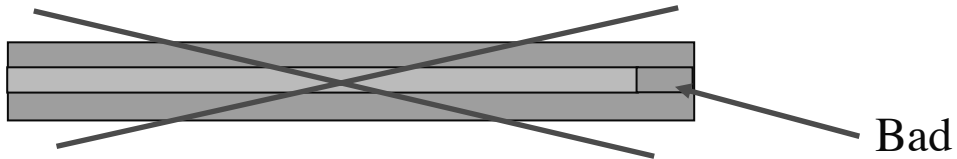

- 2- Introduce the wire until reaching the bottom of the orange opening



- 2- Introduce the wire until reaching the bottom of the orange opening

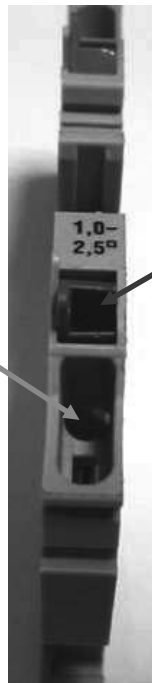

- 3- Insert a 3,5 mm diameter screwdriver in the blue opening until reaching the bottom of the blue opening. Lock the mechanism in lifting the screwdriver.

- 4- Check good holding in slightly pulling the cable.

Appendix 2 : Bitzer operating instructions for oil level control OLC-K1

für 4VCS-6.2(Y) .. 4NCS-20.2(Y) ab Seriennummer 166811090 4FC-3.2(Y) .. 4CC-9.2(Y) mit speziellem Lagerdeckel	for 4VCS-6.2(Y) .. 4NCS-20.2(Y) from serial number 166811090 4FC-3.2(Y) .. 4CC-9.2(Y) with special bearing cover	pour 4VCS-6.2(Y) .. 4NCS-20.2(Y) à partir du no. de série 166811090 4FC-3.2(Y) .. 4CC-9.2(Y) avec couvercle de palier spécial
Inhalt	Content	Sommaire
1 Anwendung 2 Technische Merkmale 3 Elektrischer Anschluss 4 Montage	1 Application 2 Technical features 3 Electrical connection 4 Mounting	1 Application 2 Caractéristiques techniques 3 Raccordement électrique 4 Montage
1 Anwendung	1 Application	1 Application
<p>Für die Lebensdauer eines Verdichters ist ausreichende Ölversorgung sehr wichtig. Ein Ausfall der Schmierung z. B. durch Ölmenge kann zu schweren Schäden am Triebwerk führen.</p> <p>Das neu entwickelte Schutzsystem OLC-K1 überwacht die Ölversorgung von Verdichtern mit Zentrifugalschmierung. Dieses System wird besonders für Anlagen mit weitverzweigtem Rohrnetz empfohlen oder in Anwendungen, bei denen sich größere Mengen Öl zur Niederdruckseite verlagern können (z. B. kritische Strömungsgeschwindigkeiten bei Teillast).</p> <p>Die Ölversorgung des Verdichters wird direkt im Bereich der Ölzufuhr zu den Lagerstellen überwacht. Im Vergleich mit den üblichen Niveauwächtern im Kurbelgehäuse ist damit eine effektivere Schutzfunktion gewährleistet.</p>	<p>An adequate oil supply is very important for the operating life of a compressor. Lack of lubrication, e. g. due to oil shortage, can lead to serious damage of the drive gear.</p> <p>The newly developed monitoring system OLC-K1 checks the oil supply of reciprocating compressors lubricated by an oil centrifuge. This system is recommended especially for plants with a widely extended pipe work, or for applications in which larger quantities of oil can migrate to the low pressure side (e.g. critical flow velocities at part load).</p> <p>The oil supply of the compressor is monitored directly at the shaft intake to the bearings. A more effective protection function is guaranteed, compared to usual oil level monitoring devices in the crankcase.</p>	<p>Une alimentation d'huile suffisante est très importante pour la durée de vie d'un compresseur. Un défaut de lubrification par ex. par manque d'huile peut engendrer des dégâts importants sur le mécanisme d'entraînement.</p> <p>Le dispositif de protection OLC-K1 développé nouvellement surveille l'alimentation d'huile des compresseurs avec lubrification centrifuge. Ce dispositif est recommandé particulièrement pour des systèmes avec un réseau de tuyauterie très ramifié ou pour des applications, ou des grandes quantités d'huile peuvent migrer vers le côté basse pression (par ex. vitesses d'écoulement critiques en charge partielle).</p> <p>L'alimentation d'huile du compresseur est surveillée directement au point d'injection vers les paliers. En comparaison avec des dispositifs de contrôle de niveau habituels dans le carter, une fonction de protection plus effective est ainsi garantie.</p>

2 Technische Merkmale

Das OLC-K1 ist ein opto-elektronischer Ölsensor, der die Ölversorgung berührungslos mit infrarotem Licht überwacht. Es besteht aus zwei Teilen: einer Prisma-Einheit und einer opto-elektronischen Einheit (Abb. 1).

- Die Prisma-Einheit wird direkt im Bereich der Ölzufuhr zu den Lagerstellen in den Lagerdeckel eingeschraubt (Abb. 2).
- Die opto-elektronische Einheit steht nicht in direkter Verbindung mit dem Ölkreislauf. Sie wird in die Prisma-Einheit eingeschraubt und in die Steuerungslogik der Anlage integriert. Ein externes Steuergerät ist nicht erforderlich.

2 Technical features

The OLC-K1 is an opto-electronic oil sensor for contactless monitoring of the oil supply by means of infrared light. It consists of two parts: a prism unit and an opto-electronic unit (figure 1).

- The prism unit is screwed into the bearing cover directly at the oil supply areas for the bearings (figure 2).
- The opto-electronic unit is not in direct contact with the oil circuit. It is screwed into the prism unit and integrated into the control circuit of the plant. An external control module is not required.

2 Caractéristiques techniques

Le OLC-K1 est une sonde d'huile opto-électronique, qui surveille l'alimentation d'huile sans contact, par lumière infrarouge. Il se compose de deux pièces: une unité prisme et une unité opto-électronique (figure 1).

- L'unité prisme est vissée dans le couvercle de palier directement au point d'injection d'huile vers les paliers (figure 2).
- L'unité opto-électronique n'est pas en contact avec le circuit d'huile. Elle est vissée sur l'unité prisme et intégrée dans la logique de commande de l'installation. Un module de commande extérieur n'est pas nécessaire.

i Im Unterschied zum Schutzgerät INT265 ist das OLC-K1 zusätzlich mit Lauferkennung ausgestattet. Dadurch reduziert sich der Aufwand beim elektrischen Anschluss.

i In contrast to the protection device INT265, the OLC-K1 is additionally equipped with operating recognition. Thus, the electrical connection is simplified.

i A la différence du dispositif de protection INT265, le OLC-K1 est équipé en plus avec une reconnaissance de marche. Ainsi le raccordement électrique est simplifié.

Technische Daten OLC-K1	Technical data OLC-K1	Données techniques OLC-K1	
Anschluss-Spannung	Supply voltage	Tension d'alimentation	230 V AC ± 10% *
Netzfrequenz	Supply frequency	Fréquence du réseau	50 / 60 Hz
Relais-Ausgänge: Schaltspannung Schaltstrom Schaltleistung	Relay output: Switching voltage Switching current Switching capacity	Sorties de relais: Tension de commutation Intensité de commutation Puissance de commutation	max. 250 V AC max. 2.5 A max. 300 VA
Vorsicherung für Gerät und Schaltkontakte	Fusing for device and switch contacts	Fusible pour appareil et contacts de commutation	max. 4 A
maximal zulässiger Druck	Maximum allowable pressure	Pression maximale admissible	32 bar
Schutzart (montiert)	Enclosure class (mounted)	Classe de protection (monté)	IP54
Anschlusskabel	Connecting cable	Câble de raccordement	6 x AWG 20 (0.5 mm ²) L = 1 m ①
Kältemittel	Refrigerants	Fluides frigorigènes	HFKW, (H)FCKW HFC, (H)CFC ②
zulässige Umgebungstemperatur	Allowable ambient temperature	Température ambiante admissible	-30 .. +60°C
Gewicht	Weight	Poids	160 g

* andere Spannungen auf Anfrage, auch mit UL-Abnahme erhältlich

① Kabel farbkodiert

② nicht zugelassen für NH₃ und Kohlenwasserstoffe

* other voltages upon request, also available with UL approval

① Cables color coded

② not admitted to NH₃ and hydrocarbons

* d'autres types de tension sur demande, aussi avec contrôle UL

① Câbles avec code couleur

② non admis pour NH₃ et hydrocarbures

2.1 Funktion

Betriebsbereit

Mit dem Einschalten des Verdichters wird die Überwachung der Ölversorgung aktiv (Lauf-Erkennung).

Verriegeln

Wenn ein Ölmenge länger als die Verzögerungszeit andauert, wird der Verdichter abgeschaltet.

Verzögerungszeit:

- nach Verdichterstart 90 s
- im Betrieb 5 s

Das OLC-K1 öffnet dann den Ausgangskontakt und verriegelt elektronisch: Die Steuerspannung zum Verdichterschütz wird unterbrochen. Die rote LED auf der Stirnseite der opto-elektronischen Einheit (Abb. 1) und die Signallampe H2 leuchten.

Entriegeln

Das OLC-K1 kann über eine Reset-Taste manuell zurück gesetzt werden. Diese Reset-Taste (S3) muss im Schaltschrank montiert werden. (Anschluss siehe Prinzipschaltbild.)

- Vor dem Entriegeln Ursache für die Störung der Ölversorgung ermitteln und beseitigen.
- Spannungsversorgung (L/N) mindestens 5 Sekunden lang unterbrechen.

2.1 Function

Ready-to-operate

The oil supply monitoring is activated when the compressor is switched on (operating recognition).

Lock out

If the lack of oil takes longer than the delay time, the compressor is shut off.

Delay time:

- after compressor start 90 s
- in operation 5 s

The OLC-K1 then opens the output contact and locks out electronically: The control voltage to the compressor contactor is interrupted. The red LED at the face side of the opto-electronic unit lights up (figure 1) as well as the signal lamp H2.

Reset

The OLC-K1 can be manually reset by pressing the reset button. This reset button (S3) has to be mounted into the switch board. (Connection see schematic wiring diagram.)

- Before resetting, determine the reason for the oil supply problem and fix it.
- Interrupt supply voltage (L/N) for at least 5 seconds.

2.1 Fonctionnement

Prêt à fonctionner

Avec la mise en marche du compresseur, le contrôle d'alimentation d'huile devient actif (reconnaissance de marche).

Verrouiller

Quand le manque d'huile dure plus longtemps que la temporisation, le compresseur est mis à l'arrêt.

Temporisation:

- après la mise en service 90 s
- en service 5 s

Le OLC-K1 ouvre alors le contact de sortie et verrouille électroniquement: la tension de commande du contacteur du compresseur est coupée. La LED rouge sur le côté frontal de l'unité opto-électronique s'allume (figure 1) et aussi la lampe H2.

Déverrouiller

Le OLC-K1 peut être remis manuellement en fonctionnement par la touche de reset. Cette touche (S3) devra être montée dans l'armoire électrique. (Raccordement voir schéma de principe.)

- Avant déverrouillage: déterminer la cause du défaut d'alimentation d'huile et y remédier.
- Interrompre la tension d'alimentation (L/N) durant 5 secondes minimum.

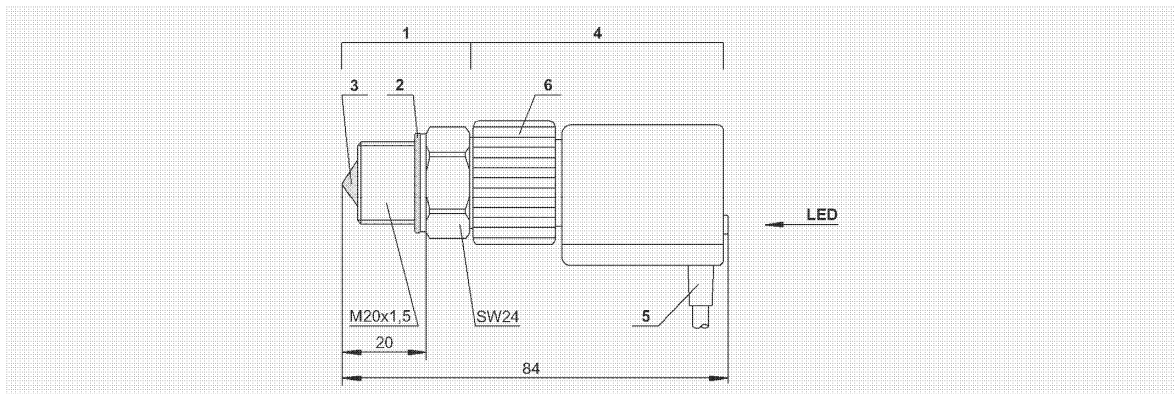

- 1 Prisma-Einheit
- 2 Kupfer-Dichtscheibe
- 3 Glas-Kegel
- 4 Opto-elektronische Einheit (360° drehbar)
- 5 Anschlusskabel
- 6 Schraubkappe

Abb. 1 Abmessungen und Aufbau

- 1 Prism unit
- 2 Copper sealing washer
- 3 Glass cone
- 4 Opto-electronic unit (360° revolving)
- 5 Connecting cable
- 6 Screwing cap

Fig. 1 Dimensions and design

- 1 Unité prisme
- 2 Rondelle d'étanchéité en cuivre
- 3 Cône en verre
- 4 Composant opto-électronique (mobile sur 360°)
- 5 Câble de raccordement
- 6 Bouchon fileté

Fig. 1 Dimensions et construction

3 Elektrischer Anschluss

OLC-K1 entsprechend Prinzipschaltbild anschließen. Reset-Tasten S2 und S3 im Schaltschrank montieren.

Das folgende Prinzipschaltbild gilt für Teilwicklungs-Anlauf. Bei Direktstart entfallen K2, K1T und Y1.

Legende

B1Steuereinheit
B2Steuereinheit des Leistungsreglers (Option)
F1Hauptsicherung
F2Verdichter-Sicherung
F3Steuersicherung
F5Hochdruckschalter
F6Niederdruckschalter
F12Sicherung der Ölsumpfheizung
F13Überstrom-Relais "Motor" PW1 (empfohlen)
F14Überstrom-Relais "Motor" PW2 (empfohlen)
H1Signallampe "Übertemperatur (Motor und Druckgas)" sowie "Störung der Ölversorgung"
H2Signallampe "Störung der Ölversorgung"
K1Schütz "1. Teilwicklung"
K2Schütz "2. Teilwicklung"
K1TZeitrelais "Teilwicklung"
K2TZeitrelais "Pausenzeit" 300 s
M1Verdichter
Q1Hauptschalter
R1-6PTC-Fühler in Motorwicklung
R7Druckgas-Temperaturfühler (Option)
R8Ölsumpfheizung (Option)
S1Steuerschalter
S2Entriegelung "Übertemperatur (Motor / Druckgas)"
S3Entriegelung "Ölmangel"
U1EMV-Entstörglied (bei Bedarf)
Y1Magnetventil "Anlaufentlastung" (Option)
Y2Magnetventil "Flüssigkeitsleitung"
Y3Magnetventil "Leistungsregelung" (Option)
SE-B1 / SE-B2Verdichter-Schutzgerät
OLC-K1Überwachung der Ölversorgung

3 Electrical connection

Connect OLC-K1 according to schematic wiring diagram. Mount reset buttons S2 and S3 into switch board.

The following schematic wiring diagram applies to part winding start. For direct start K2, K1T and Y1 can be omitted.

Legend

B1Control unit
B2Control unit of capacity regulator (option)
F1Main fuse
F2Compressor fuse
F3Control circuit fuse
F5High pressure cut out
F6Low pressure cut out
F12Fuse of crankcase heater
F13Thermal overload "motor" PW1 (recommended)
F14Thermal overload "motor" PW2 (recommended)
H1Signal lamp "over temperature (motor and discharge gas)" and "oil supply fault"
H2Signal lamp "oil supply fault"
K1Contactor "first PW"
K2Contactor "second PW"
K1TTime relay "part winding"
K2TTime relay "pause time" 300 s
M1Compressor
Q1Main switch
R1-6PTC sensors in motor windings
R7Discharge gas temperature sensor (option)
R8Crankcase heater (option)
S1Control switch
S2Fault reset "over temperature (motor / discharge gas)"
S3Fault reset "lack of oil"
U1EMC screening unit (if required)
Y1Solenoid valve "start unloading" (option)
Y2Solenoid valve "liquid line"
Y3Solenoid valve "capacity control" (option)
SE-B1 / SE-B2Compressor protection device
OLC-K1Oil supply monitoring

3 Raccordement électrique

Raccorder le OLC-K1 suivant le schéma de principe. Monter les touches de reset S2 et S3 dans l'armoire électrique.

Le schéma de principe s'applique au démarrage à bobinage partiel. En démarrage direct K2, K1T et Y1 sont laissés à côté.

Légende

B1Unité de commande
B2Unité de commande du régulateur de puissance (option)
F1Fusible principal
F2Fusible compresseur
F3Fusible protection de commande
F5Pressostat haute pression
F6Pressostat basse pression
F12Fusible de résistance de carter
F13Relais thermique de moteur PW1 (recommandé)
F14Relais thermique de moteur PW2 (recommandé)
H1Lampe "excès de température" (moteur et gaz de refoulement) et "défaut d'alimentation d'huile"
H2Lampe "défaut d'alimentation d'huile"
K1Contacteur "bobinage 1"
K2Contacteur "bobinage 2"
K1TRelais temporisé "bobinage partiel"
K2TRelais temporisé "pause" 300 s
M1Compresseur
Q1Interrupteur principal
R1-6Sondes PTC dans les bobinages du moteur
R7Sonde de température du gaz de refoulement (option)
R8Résistance de carter (option)
S1Commutateur de commande
S2Réarmement "excès de température" (moteur et gaz de refoulement)
S3Réarmement "manque d'huile"
U1Élément d'antiparasitage de CEM (si nécessaire)
Y1Vanne magnétique "démarrage à vide" (option)
Y2Vanne magnétique "conduite de liquide"
Y3Vanne magnétique "régulation de puissance" (option)
SE-B1 / SE-B2Dispositif de protection du compresseur
OLC-K1Contrôle d'alimentation d'huile

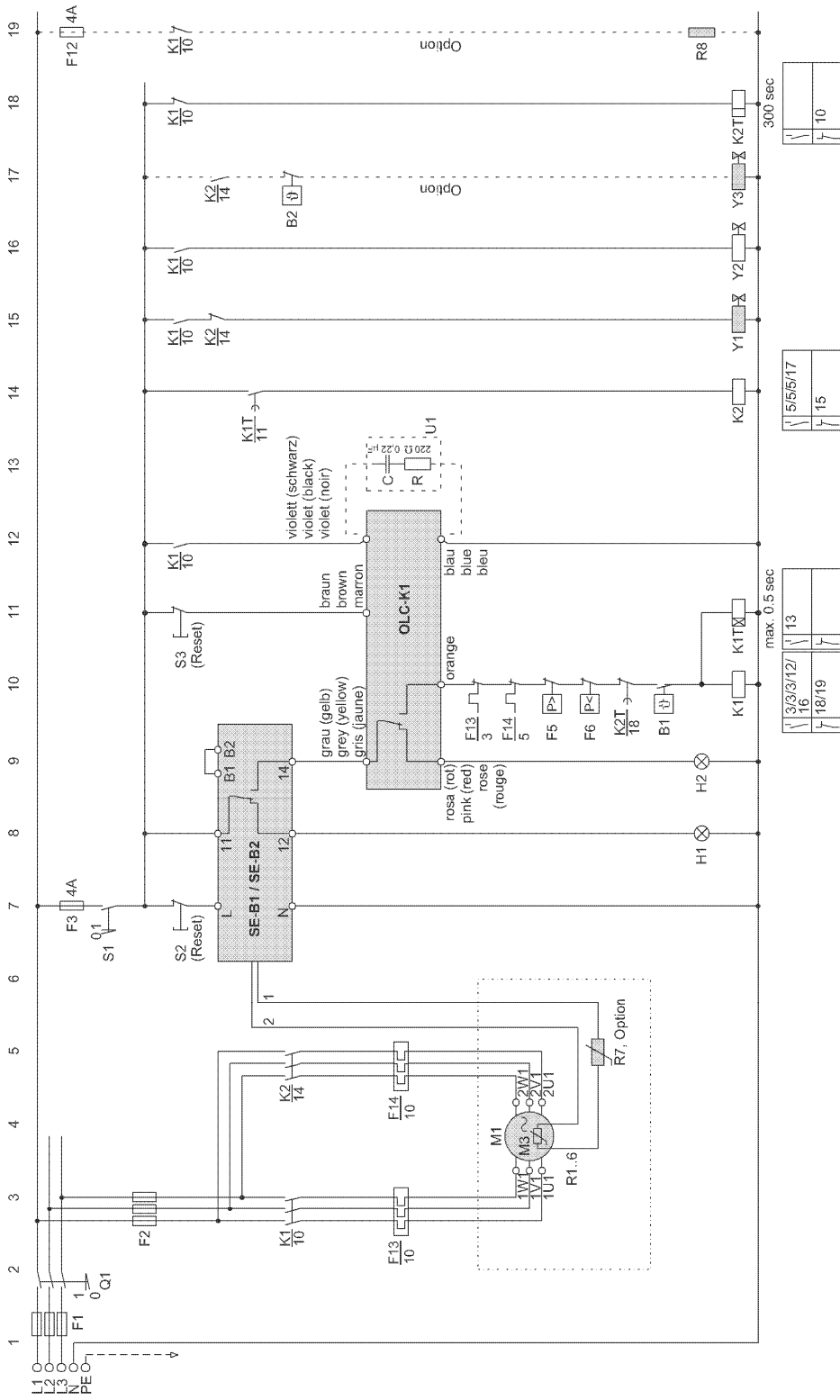

4 Montage

OLC-K1 vorzugsweise montieren, bevor der Verdichter in die Anlage eingebaut wird.



Warnung!

Verdichter steht unter Druck!
Schwere Verletzungen möglich.
Verdichter auf drucklosen Zustand bringen!
Schutzbrille tragen!

- Verdichter kippen, indem er an der Unterseite des Lagerdeckels angehoben wird, damit das in der Öltasche des Lagerdeckels befindliche Öl nicht durch die Anschlussbohrung abfließen kann.
- Schraube (M20x1,5) am Lagerdeckel ausschrauben und Gewindeloch reinigen.
- Glaskegel der Prisma-Einheit innen und außen auf Sauberkeit prüfen und ggf. reinigen.
- Prisma-Einheit mit Metall-Dichtung in den Lagerdeckel einschrauben. Anzugsmoment ca. 75 Nm.

4 Mounting

Mount the OLC-K1 best before the compressor is installed.



Warning!

Compressor is under pressure!
Serious injuries are possible.
Release the pressure in the compressor!
Wear safety goggles!

- Tilt the compressor by lifting it at the bottom side of the bearing cover in order to keep the oil in the oil pocket of the bearing cover from draining through the connection bore.
- Remove the screw (M20x1,5) at the bearing cover and clean the threaded hole.
- Check if glass cone of prism unit is clean on inside and outside and clean if necessary.
- Fit the prism unit with metal gasket into the bearing cover. Tightening torque approximately 75 Nm.

4 Montage

Monter de préférence le OLC-K1, avant que le compresseur soit incorporé dans l'installation frigorifique.



Avertissement !

Compresseur est sous pression !
Des graves blessures sont possibles.
Retirer la pression sur le compresseur !
Porter des lunettes de protection !

- Basculer le compresseur en le soulevant côté couvercle de palier (l'agripper au bas du couvercle) afin que l'huile qui se trouve dans la poche de ce même couvercle ne s'écoule pas par l'alésage de raccordement.
- Dévisser la vis (M20x1,5) du couvercle de palier et nettoyer le trou taraudé.
- Vérifier la propreté du cône en verre de l'unité prisme à l'intérieur et à l'extérieur et le nettoyer, si nécessaire.
- Visser l'unité prisme avec joint métallique dans le couvercle de palier. Couple de serrage environ 75 Nm.



Abb. 2 OLC-K1 montieren

Fig. 2 Mounting of OLC-K1

Fig. 2 Monter le OLC-K1

- Opto-elektronische Einheit sorgfältig in die Prisma-Einheit bis zum Anschlag einschieben und Schraubkappe von Hand fest anziehen.

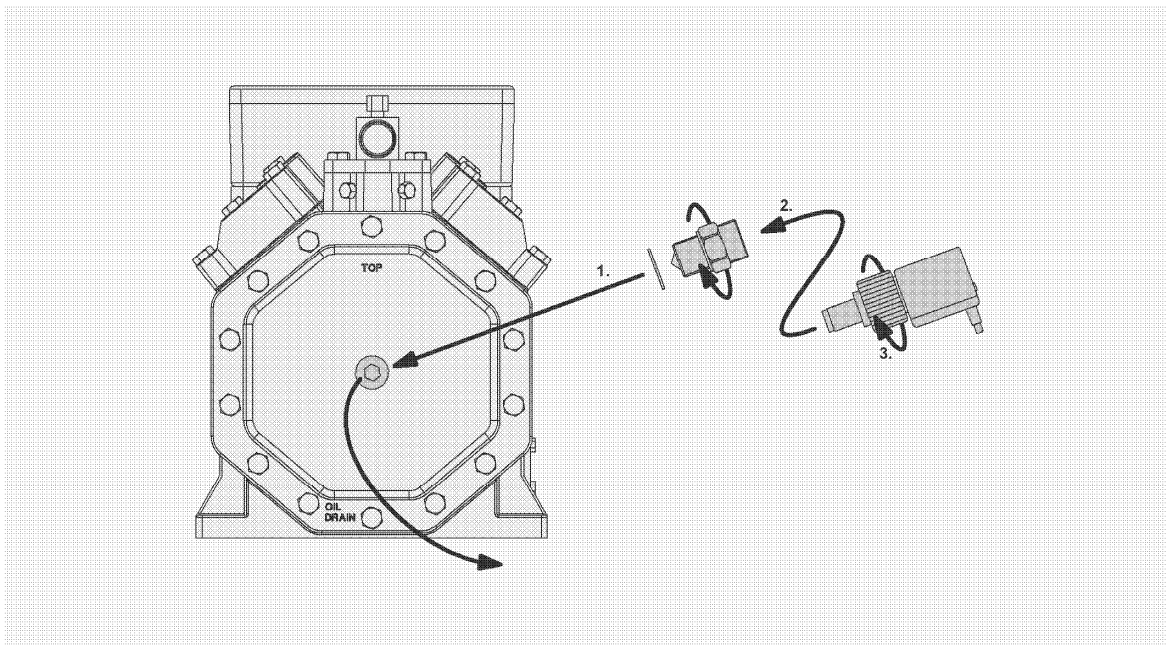
! Achtung!
 Ausfall des Schutzgeräts möglich!
 Unmittelbar vor dem Einschrauben der opto-elektronischen Einheit sicherstellen, dass die Prisma-Einheit trocken ist!
 Kondenswasser sorgfältig entfernen!

! Achtung!
 Gefahr von Verdichterausfall!
 Zerstörung des Schutzgeräts durch eintretende Feuchtigkeit möglich!
 Sicherstellen, dass der Kabelanschluss immer nach unten weist!

- Opto-elektronische Einheit keinesfalls demontieren!

- Slide the opto-electronic unit carefully into the prism to the stop and firmly tighten the screwing cap manually.

! Attention!
 Possible failure of protection device!
 Immediately before screwing in the opto-electronic unit, ensure that the prism is dry!
 Remove condensing water carefully!

! Attention!
 Danger of compressor breakdown!
 Moisture ingress may destroy the protection device!
 Ensure that the cable connection always points downwards!

- In no case dismount the opto-electronic unit!

- Glisser l'unité opto-électronique soigneusement dans l'unité prisme jusqu'à la butée et serrer fermement le bouchon fileté, à la main.

! Attention !
 Défaillance du dispositif de protection possible !
 Immédiatement avant de serrer la vis de l'unité opto-électronique, il faut garantir que l'unité prisme est sèche.
 Enlever soigneusement l'eau condensation !

! Attention !
 Danger de défaillance du compresseur !
 Destruction du dispositif de protection possible par introduction d'humidité !
 Garantir que le raccordement de câble est toujours dirigé vers le bas.

- En aucun cas, démonter l'unité opto-électronique !

Oil Pressure Monitoring

Types

Semi-hermetic and open drive BITZER reciprocating compressors with integrated oil pump Content

1 General

An adequate oil supply is very important for the operating life of a compressor. Lack of lubrication e. g. due to oil shortage can lead to serious damage of bearings and sliding surfaces. BITZER offers two systems for monitoring the oil pressure of pump lubricated reciprocating compressors: in addition to the externally mounted differential oil pressure switches also an incorporated sensor Delta-PII is available. It is directly screwed into the pump housing (bearing cover). The main advantage is that tube connections, with the danger of breakage, are not used between compressor and differential oil pressure switch.

Thus the mounting effort is reduced and the safety in view of leakages is increased at the same time.

2 Differential oil pressure switch Delta-PII

2.1 Technical features

- The differential oil pressure switch Delta-PII consists of two parts: a sensor unit and an electronic unit (fig. 1).
- The sensor unit is screwed directly into the pump housing of the compressor (bearing cover, fig. 2). It contains a switching element which is connected by channels with the suction and discharge pressure of the oil pump. Therefore external tubes and flare connections are omitted.
- The electronic unit is not in direct contact with the oil circuit. It is screwed into the sensor unit. Thus, the mounting and dismantling is possible without intervention into the refrigeration circuit. An external control module is not required. • The red LED at front end of the electronic unit (fig. 1) signals the operating condition of Delta-PII while compressor is running.

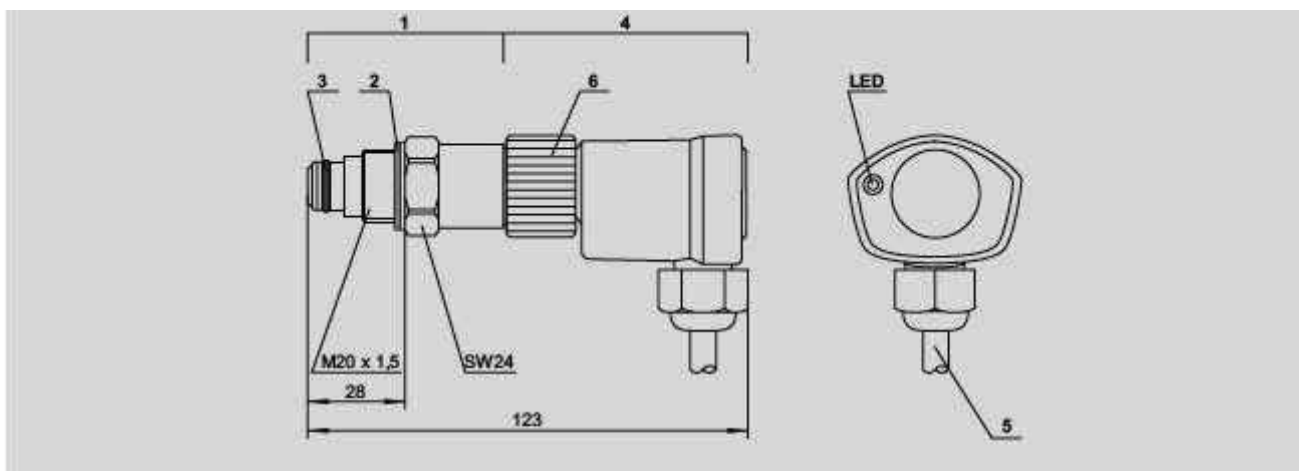

- 1 Sensor-Einheit
- 2 Metall-Dichtscheibe
- 3 O-Ring
- 4 Elektronische Einheit (360° drehbar)
- 5 Anschlusskabel
- 6 Schraubkappe

- 1 Sensor unit
- 2 Metal sealing washer
- 3 O-ring
- 4 Electronic unit (360° revolving)
- 5 Connecting cable
- 6 Screwing cap

- 1 Unité de sonde
- 2 Rondelle d'étanchéité métallique
- 3 Joint annulaire
- 4 Unité électronique (mobile sur 360°)
- 5 Câble de raccordement
- 6 Bouchon fileté

Abb. 1 Abmessungen und Aufbau des Delta-PII

Fig. 1 Dimensions and design of the Delta-PII

Fig. 1 Dimensions et construction de Delta-PII

The Delta-PII is optionally available as a pure switching device (with REED contact) – e. g. for PLC control. Time delay must then be integrated into the control logic.

2.2 Technical data

- Operating voltage: 115 .. 230 V AC +10% / -15%, 50/60 Hz also available with UL approval
- Power consumption: 3 VA
- Relay output: Switch voltage 250 V ~ Switching current max. 2.5 A Switching capacity 300 VA ind.
- Connecting cables: 6 x AWG18 (0,75 mm²) L = 1 m color coded
- Differential cut-out pressure: 0,65 bar
- Time delay with insufficient differential oil pressure: 90 s ± 5 s
- Lock out: electrical
- Admissible ambient temperature: -30°C .. +70°C
- Fuse for protection device and switch contacts: max. 6 A
- Enclosure class: IP54 when electronic unit is mounted and connecting cable points downwards
- Refrigerants: HFC, (H)CFC not admitted to NH3
- Weight: 200 g

2.3 Function Compressor start

The oil pressure monitoring is activated when supply voltage is applied via an auxiliary contact of the motor contactor K1 (operating recognition, see also schematic wiring diagram). The LED at the front end of the electronic unit immediately signals an insufficient differential oil pressure.

Operation

Once the preset value has been reached, this LED extinguishes. The output contact remains closed if the differential oil pressure reaches or exceeds the preset value.

Differential oil pressure below preset value

If the differential oil pressure remains or drops below the preset value for longer than the time delay (approx. 90 s), the output contact opens. The Delta-PII locks out and shuts off the compressor. The signal lamp H2 and the LED at the protection device both stay on until Delta-PII has been reset. Shorter times of insufficient oil pressure are also recognised by the internal microprocessor. They also lead to a compressor shut-off after a correspondingly extended time delay (time integration).

Manual reset

Interrupt power supply (L/N) for at least 5 seconds (reset button S3, see schematic wiring diagram).

Fault of Delta-PII

In case the supply voltage is too low or if the electronic unit is not completely mounted, the Delta-PII locks out. The LED at the front end of the electronic unit is flashing.

LED indications

- LED is on: lack of oil The signal lamp H2 is also on.
- LED is flashing: fault of Delta-PII
- LED is off: sufficient oil supply

2.4 Mounting

Warning!

Compressor is under pressure! Serious injuries are possible. Release the pressure in the compressor! Wear safety goggles!

- Close the shut-off valves at the compressor and release the pressure in the compressor.
- Unscrew the plug (or mounted pressure sensor) at the bearing cover and clean the threaded hole.
- Fit the sensor unit with o-ring and metal sealing washer into the bearing cover. Mount the o-ring very carefully, do not damage it! Tightening torque approx. 75 Nm.
- Slide the electronic unit to the stop and firmly tighten the screwing cap manually. This unit is freely revolving. Position connecting cable facing downwards.

Attention!

- Moisture ingress may destroy the protection device! Ensure that the connecting cable always points downwards!
- Connect cables according to schematic wiring diagram (see chapter 2.5).



Abb. 2 Öldifferenzdruck-Schalter Delta-PII montieren.

Fig. 2 Mounting the differential oil pressure switch Delta-PII.

Fig. 2 Monter le pressostat différentiel d'huile Delta-PII.

2.5 Electrical connection

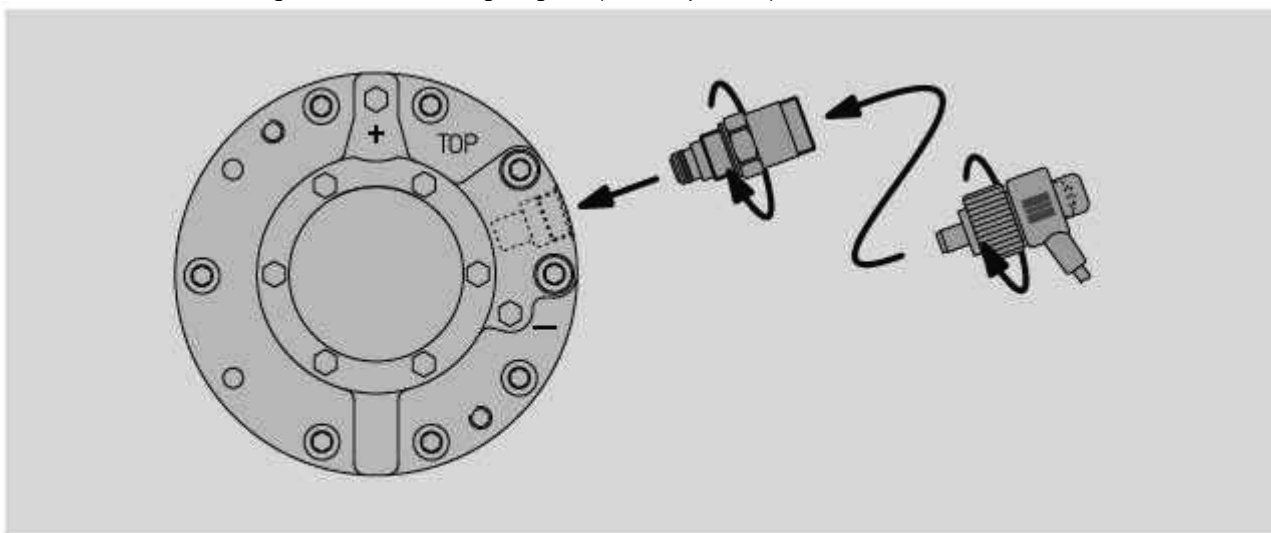
Connect Delta-PII according to schematic wiring diagram. Mount reset buttons S2 and S3 into switch board. The following schematic wiring diagram applies to part winding start. For direct start K2, K1T and Y1 can be omitted.

Legend

- B1Control unit
- B2Control unit of capacity regulator (option)
- F1Main fuse
- F2Compressor fuse
- F3Control circuit fuse
- F5High pressure cut out
- F6Low pressure cut out
- F12Fuse of crankcase heater
- F13Thermal overload "motor" PW1 (recommended)
- F14Thermal overload "motor" PW2 (recommended)
- H1Signal lamp "over temperature (motor and discharge gas)" and "oil supply fault"
- H2Signal lamp "oil supply fault"
- K1Contactor "first PW"
- K2Contactor "second PW"
- K1TTime relay "part winding"
- K2TTime relay "pause time" 300 s
- M1.....Compressor
- Q1.....Main switch
- R1-6 ..PTC sensors in motor windings
- R7Discharge gas temperature sensor (option)
- R8Crankcase heater (option)
- S1Control switch
- S2Fault reset "over temperature (motor / discharge gas)"
- S3Fault reset "lack of oil"
- Y1Solenoid valve "start unloading" (option)
- Y2Solenoid valve "liquid line"
- Y3Solenoid valve "capacity control" (option)
- SE-B1 / SE-B2Compressor protection device
- Delta-PIIDifferential oil pressure switch

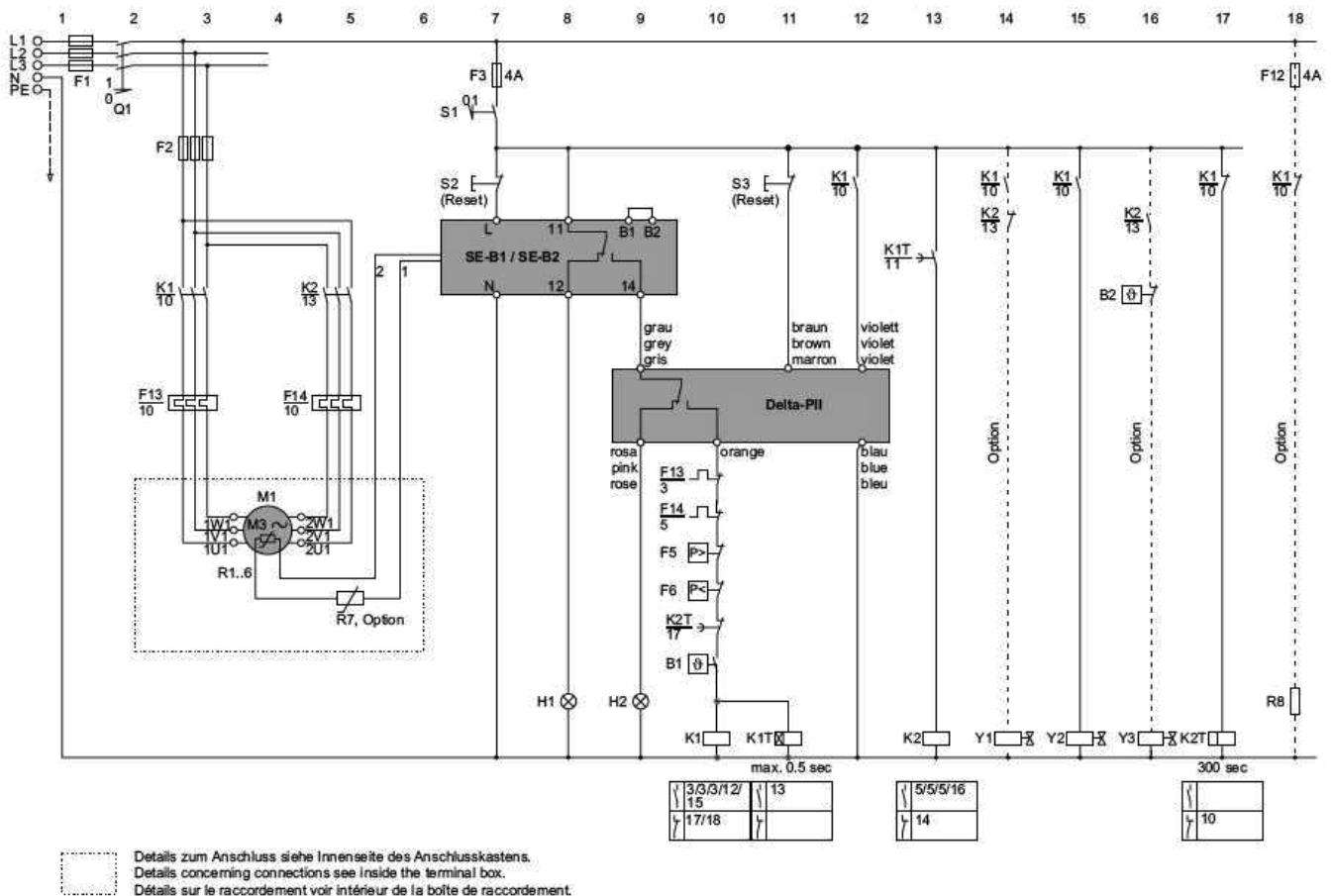

2.6 Function test

Check when the compressor is shut off. Remove the motor fuses and – if refrigerant is already charged – cut the power supply to the liquid solenoid valve(s). Switch on the control voltage. The compressor contactor (K1) closes and thus activating the differential oil pressure monitoring. With correct function the LED will be lit about 90 s. Afterwards the output contact and the compressor contactor open. The signal lamp H2 lights up additionally.

Appendix 4 : Copeland operating instructions for oil pressure monitoring "OPS1"

Application

Monitoring the oil differential pressures in refrigeration compressors. OPS1 consists of two parts: a pressure sensor and an electronic switch. It is easy to apply and due to the pre-assembled sensor environmentally friendly, the risks of refrigerant leakage are minimized.

The pressure sensor of the oil differential switch is directly screwed into the pump housing of the compressor. Internal channels link the switch to the suction and discharge ports of the oil pump. No capillary connections are necessary. The electronic switch can be fitted or removed without opening the refrigeration circuit.

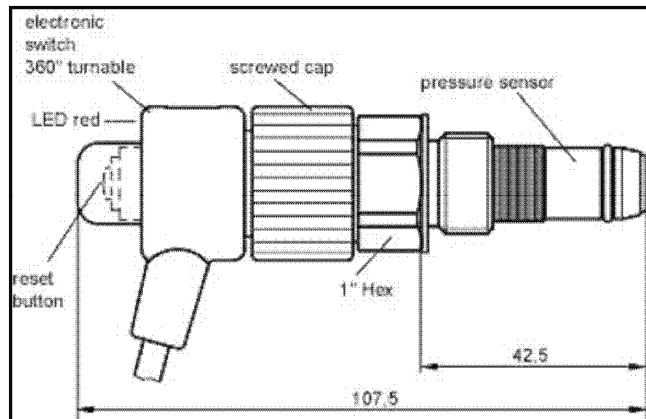

Functional description:

The differential pressure monitor is activated when the supply voltage is applied via an auxiliary contact of the motor contactor K1. A red LED signals insufficient differential oil pressure immediately. Once the pre-set value has been reached, the LED is extinguished. The output contact remains closed when the set value is reached or exceeded. If the oil differential pressure remains or drops below the set value for longer than the time delay time, the output contact opens and locks out mechanically. Depressing the reset button can reactivate the switch. Shorter periods of insufficient differential pressure are also recognised by the internal microprocessor circuitry and lead to a trip and lockout after correspondingly extended delay time (integration).



Trained electrical personnel must connect the unit. All valid standards for connecting electrical and refrigeration equipment must be observed. Limit values for the supply voltage of the unit may not be exceeded. The oil differential switch needs no maintenance.

Technical data:	
Supply voltage	AC 50/60 Hz 230V +/- 10% 10VA
Ambient temperature range	-30.....+60°C
Time delay	120 s
Cut-in pressure (fixed)	0,95 bar +/- 0,15 bar
Cut-out pressure (fixed)	0,63 bar +/- 0,15 bar
Switching capacity	AC 250 V, max. 2,5A, 720 VA ind.
Refrigerant compatibility	yes (brass)
Protection class according EN 60529	IP54
Reset	manual
Connection cable	4xAWG20 (0,5 mm ²), L=1m colour coded cores
Weight	ca. 200 g

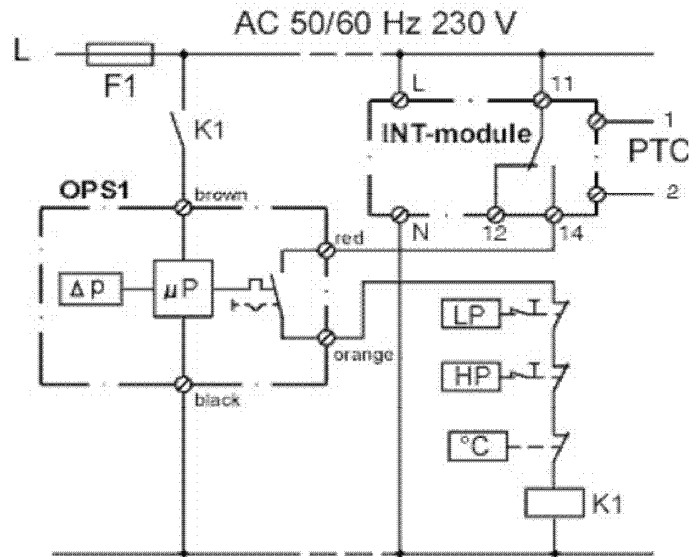

Wiring diagram OPS 1 with aux. relay KD
(alarm-integration)

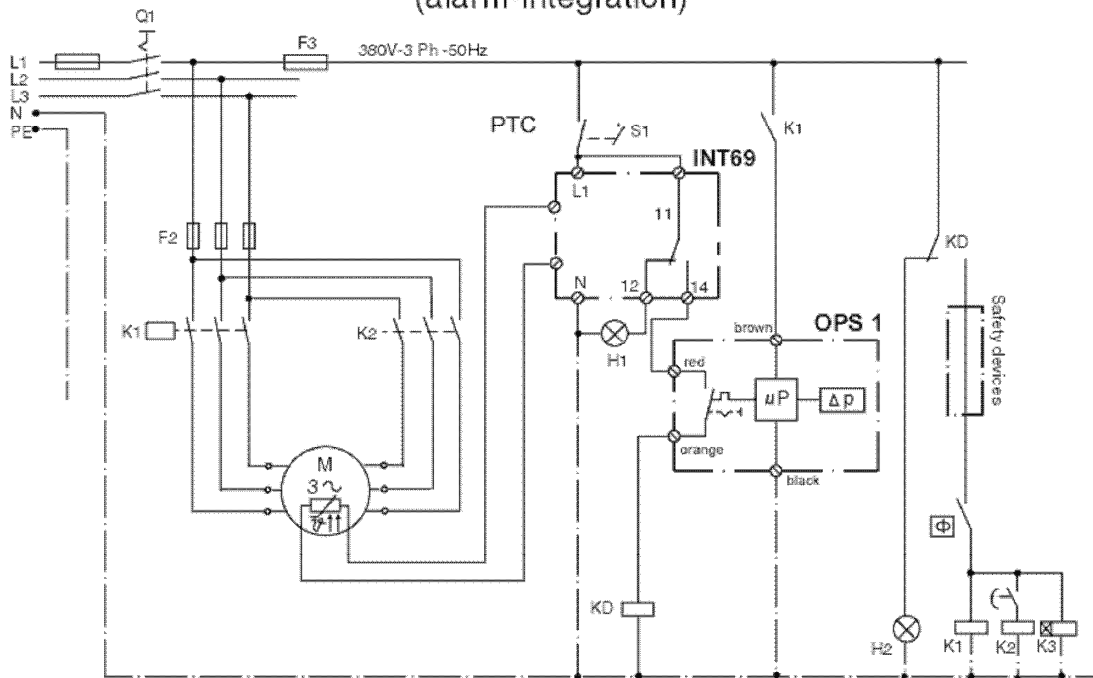



INT275 L[®] Level monitoring

INT275 L[®]



INT275 L

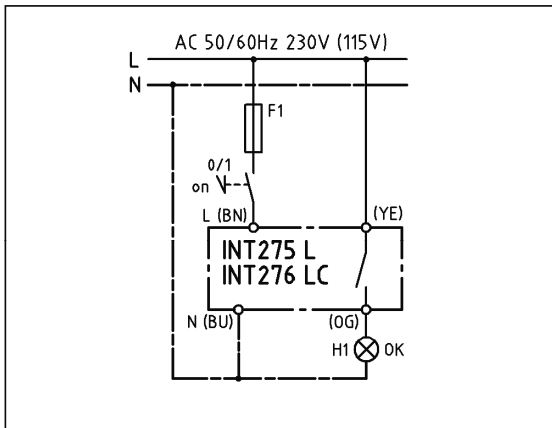

Connection diagram

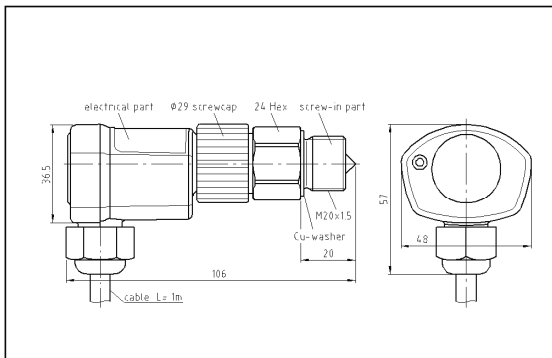

Dimensions in mm

⚠ The unit must be connected by trained electrical personnel. All valid standards for connecting elec-

trical equipment must be observed. Limit values for the supply voltage of the unit may not be exceeded.

Application:

The optical sensor INT275 L is developed for contactless level monitoring of liquids. A screw-in part mounted at the required location and a removable electrical part perform this function. The electrical part can be fitted or removed without opening the liquid tank. When the supply voltage is applied, the relay switches on after about 3s.

On absence of liquid or when a fault occurs the relay trips after a delay. When liquid is present or the fault disappears, the relay pulls in after a delay. The potential free normally open contact can be directly wired in a control circuit without an additional auxiliary relay. An integrated self-monitoring circuit ensures high reliability. A mounting check eliminates wrong installation or manipulation.

Installation instruction:

Mounting:
The installer must ensure seal tightness for the specific application. The maximum tightening torque is approx. 75Nm. Clean the inside of the screw-in part as well as the prism. Fit the electrical part in the screw-in part and tighten

the coupling ring (torque approx. 10Nm). Pay attention to the position of the lead (cable exit downwards). Complete the electrical wiring in accordance with the attached circuit suggestions. After filling the tank, check the tightness of all joints.

Technical data screw-in part

Ambient temperature range	-30...+60°C
Max. temperature at prism	+80°C
Test pressure	32bar
Housing	VA 1.4510 or 1.4305
Mounting	M20x1.5mm, wrench size 24 NPT1/2", wrench size 24
Weight	approx. 75g

Technical data electrical part

Supply voltage (52S...)	AC50/60Hz 230V ±10%
Supply voltage (41S...)	AC50/60Hz 115V ±10%
Ambient temperature range	-30...+60°C
Delays	
- Relay on after supply voltage on	3s±1s
Level monitoring active after	
Relay on	
Relay off (low level) after	5s±2s
Relay off (fault) after	5s±2s
Relay on (level high again) after	5s±2s
Relay on (fault disappears) after	5s±2s
Relay	AC250V, 2.5A, C300
Mechanical service life	approx. 10 ⁵ switching cycles
Housing	Ultradim A3XZG5
Protection class acc. to EN60529	IP54 when mounted
Mounting	coupling ring on screw-in part
Connecting cable	4xAWG18 (0.75mm ²) L=1m, colour-coded
Weight	approx. 80g

Ordering information

230V-Version: INT275 L Level monitoring	
Electrical Part	52S475S60
115V-Version: INT275 L Level monitoring	
Electrical Part	41S475S60
screw-in part M20x1.5mm	02K465
screw-in part NPT1/2"	02K460S22

Subject to technical modifications without notice

FRIGA-BOHN®



LFB France

42 rue Roger Salengro - BP 205
69741 GENAS CEDEX - FRANCE

Tél. : +33 4 72 47 13 00 - Fax : +33 4 72 47 13 96
www.frigabohn.com

Friga-Bohn se réserve le droit d'apporter toute modification sans préavis.
Friga-Bohn reserves itself the right to make changes at any time without preliminary notice.
Friga-Bohn Angaben und Abbildungen unverbindlich. Änderungen vorbehalten.
Friga-Bohn se reserva el derecho de aportar cualquier modificación sin preaviso
Friga-Bohn zastrzega sobie prawo do wprowadzania zmian bez uprzedzenia

MEGA

Condensing Units
N° IN0011700-F
04.2025