

NF Unit coolers

Notice technique d'installation
Installation instructions
Installationsnotiz
Manual tecnico de instalacion
Oryginalna instrukcja

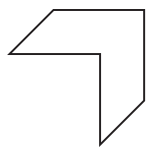

Cooling solutions, delivered with care.

www.frigabohn.com

1. DEBALLAGE ET MANUTENTION DE LA PARTIE BATTERIE REMOVING FROM PACKING AND MANIPULATION DESEMBALADO Y MANIPULACIÓN DE LA BATERÍA

Retirer les vis de fixation à la palette et soulever la batterie par les anneaux de levage (fig.1)
Remove the attaching screws and cage by the eyebolt (fig.1)
Quitar los tornillos de sujeción al palet y coger mediante los cáncamos que hay en la parte superior (fig. 1)



(Fig.1)

2. DEBALLAGE ET MANUTENTION DE LA PARTIE VENTILATION GROUP FAN REMOVING FROM PACKING AND MANIPULATION DESEMBALADO Y MANIPULACIÓN DEL TREN DE VENTILACIÓN

Retirer la plaque de fixation à la palette (fig. 2)
Remove the shape attaching (fig.2)
Quitar la chapa de sujeción al palet (fig.2)



(Fig.2)

3. DIMENSIONS - DIMENSIONAL DATA - DIMENSIONES

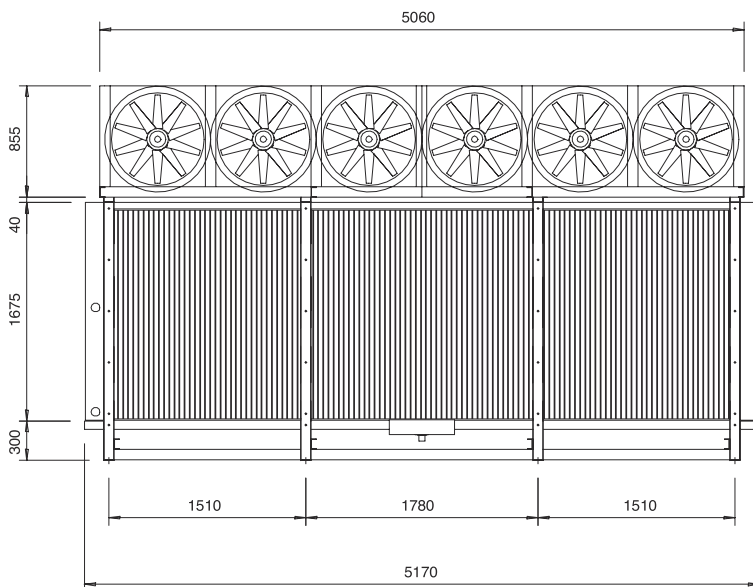
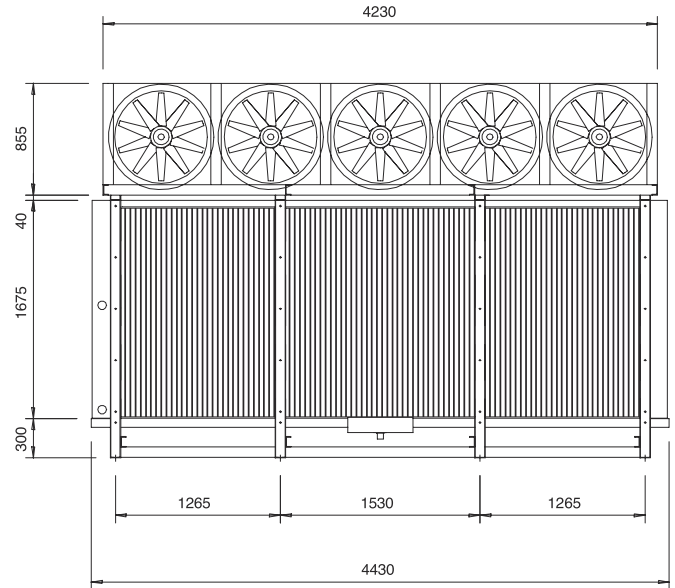
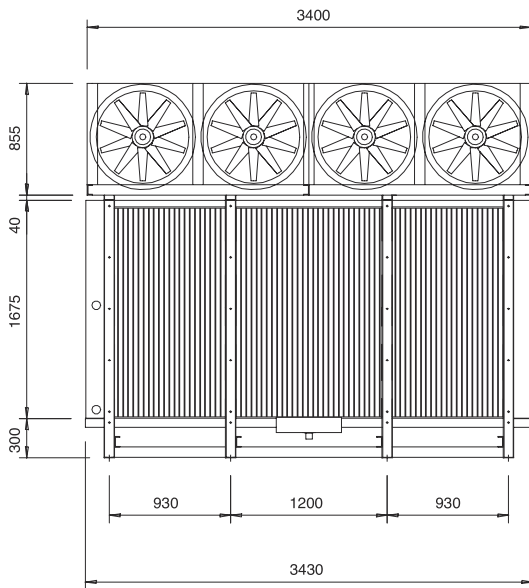
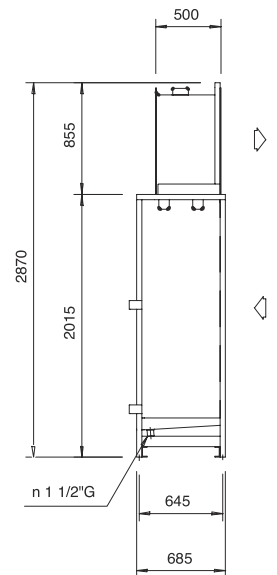
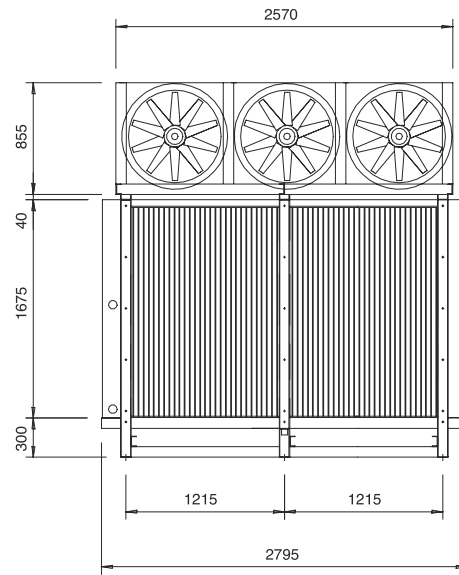
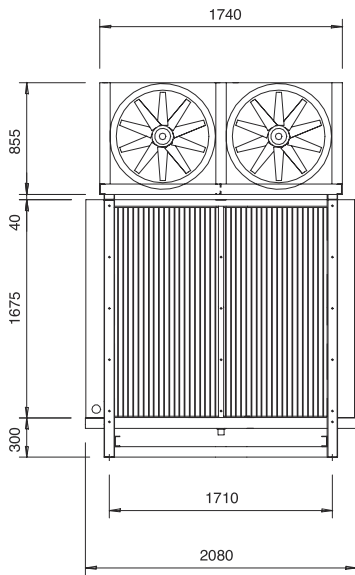

**4. MISE EN PLACE BULBE ET EGALISATION DE PRESSION
 BULB AND EXTERNAL EQUALIZER LAY-OUT
 INSTALACIÓN BULBO Y EQUILIBRADOR DE PRESIÓN**

→ ① → ②

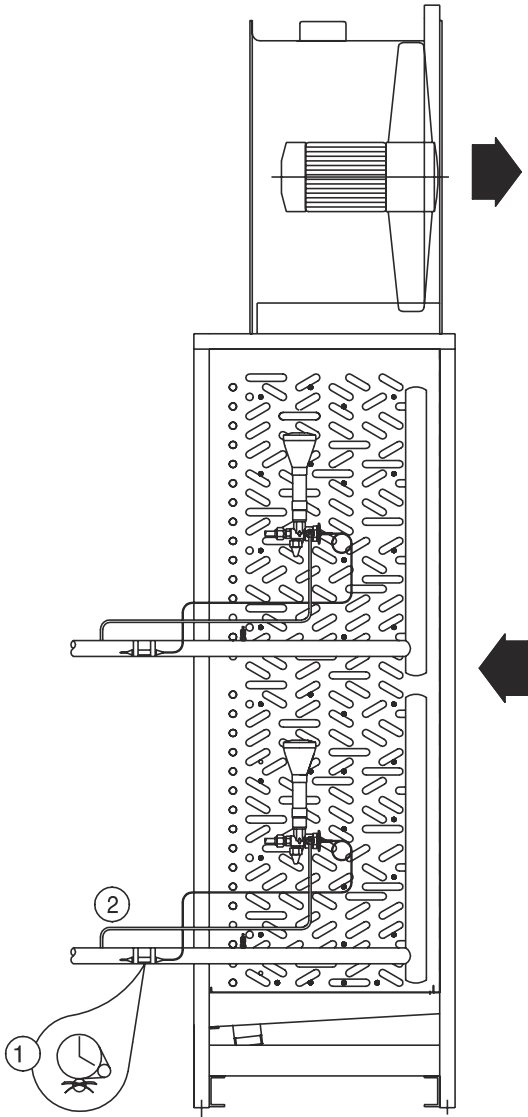

**5. MONTAGE EVAPORATEUR ET CONDUITES
 LOCATION UNIT COOLER AND PIPING
 MONTAJE EVAPORADOR Y TUBERIAS**

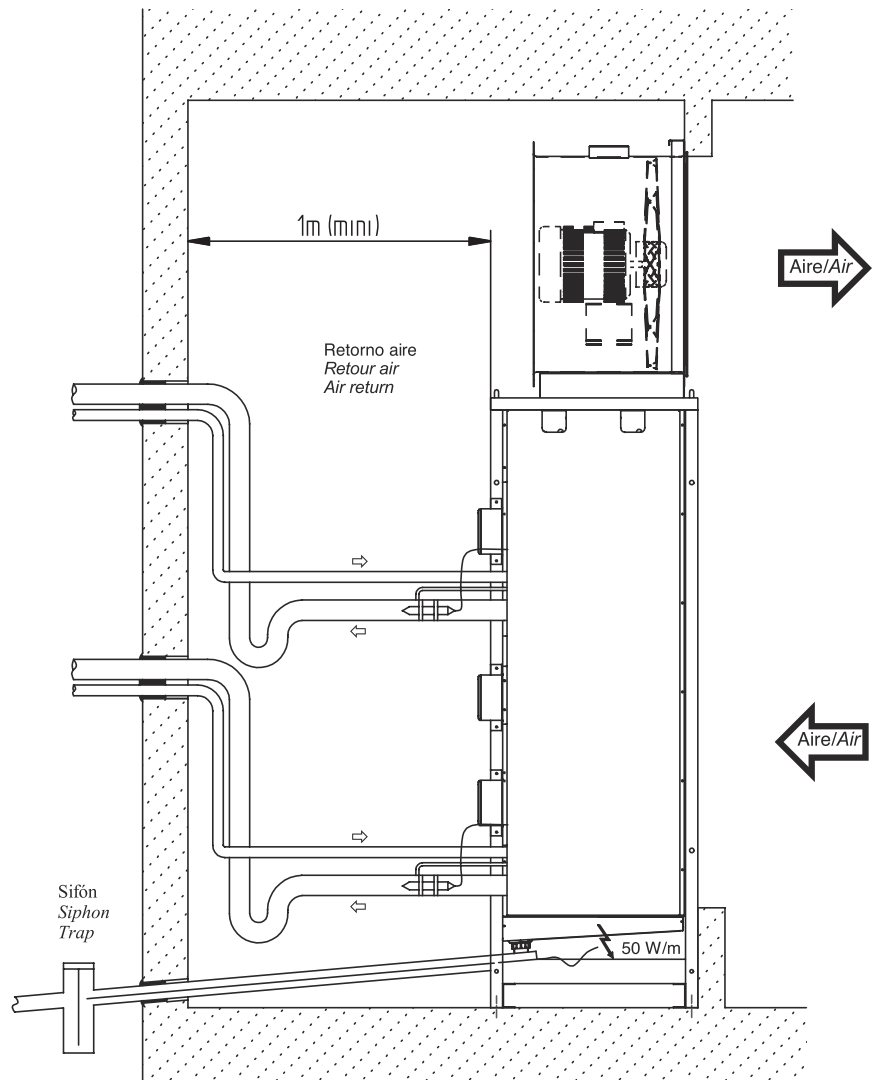

6. DEGIVRAGE ELECTRIQUE ELECTRIC DEFROST DESESCARCHE ELECTRICO

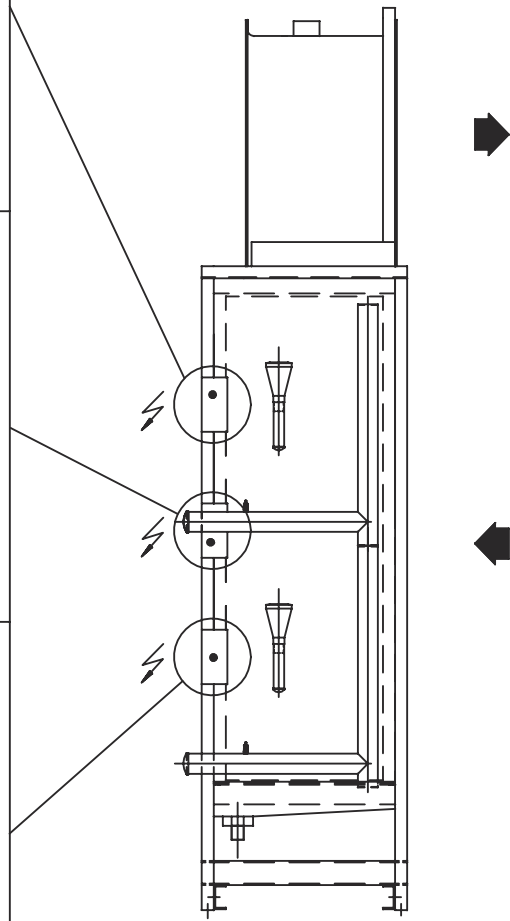
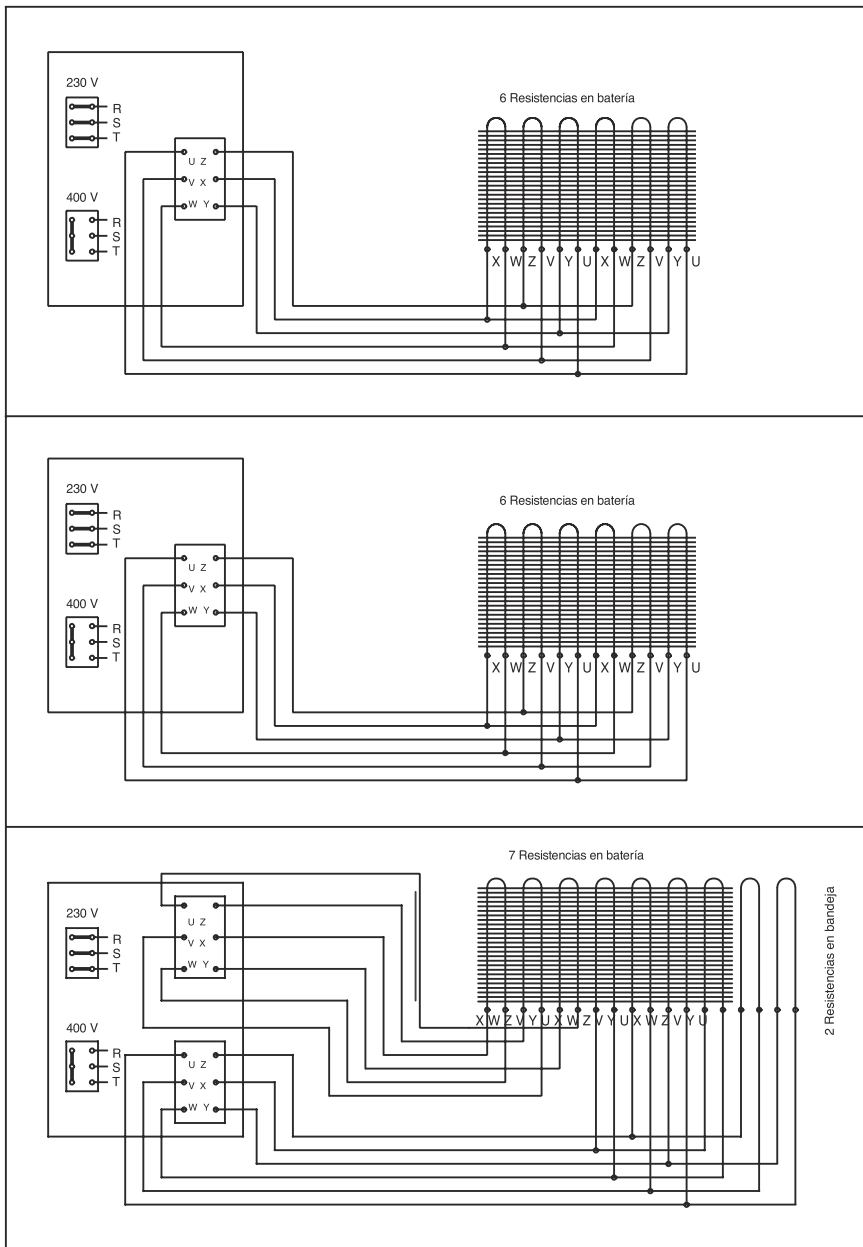

Moteur triphasé
Motor 3 phase
Motor trifasico

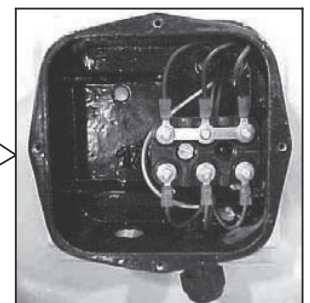
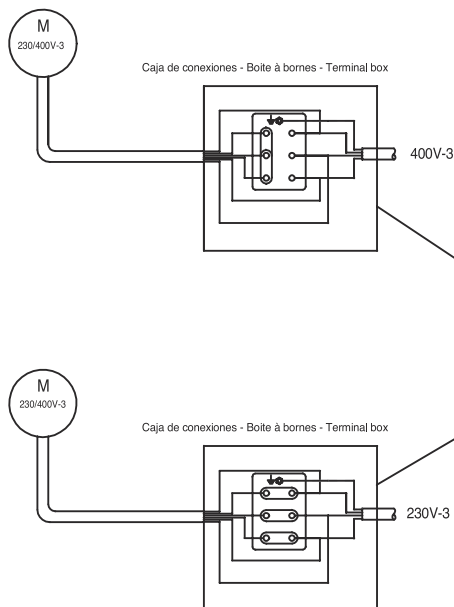

7. FIXATION DE LA PARTIE VENTILATION A LA BATTERIE FIXING GROUP FAN TO GROUP REFRIGERATOR FIJACIÓN GRUPO DE VENTILADORES A LA BANCADA DE BATERÍA

Monter le profil adaptateur avec des vis M10x35 et des rondelles (fig. 1)

Assembly the adaptor with M10x35 screws-washer (fig.1)

Montar el adaptador para fijación mediante los tornillos de M10x35 y las arandelas (fig.1)

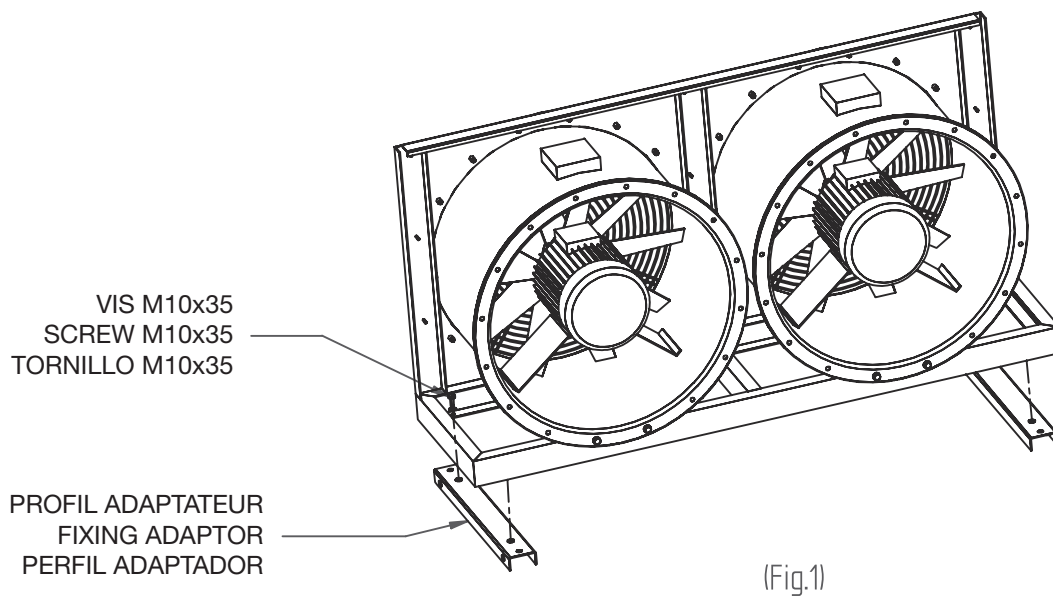

Poser la partie ventilation sur la batterie (fig. 2)

Put the group fan on the group refrigerator (fig.2)

Poner el grupo de ventiladores encima de la batería (fig.2)

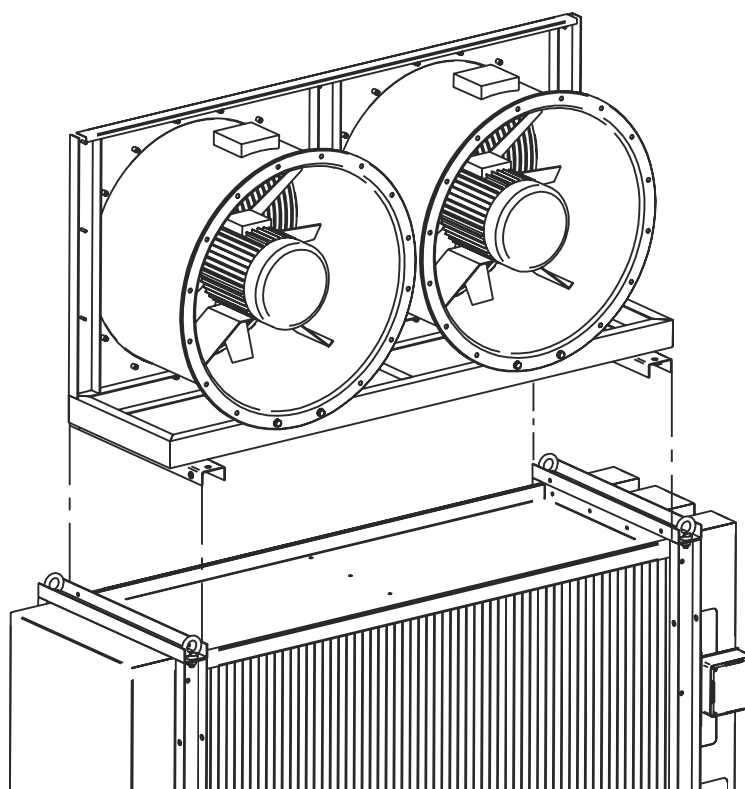

8. FIXATION DE LA PARTIE VENTILATION A LA BATTERIE
FIXING GROUP FAN TO GROUP REFRIGERATOR
FIJACIÓN GRUPO DE VENTILADORES A LA BANCADA DE BATERÍA

Fixez l'ensemble batterie/ventilation avec les vis M10x35 et les rondelles (fig.3)
Fix the assembly with M10x35 screws- washer (fig.3)
Fijar el conjunto mediante los tornillos de M10x35 y arandelas (fig.3)

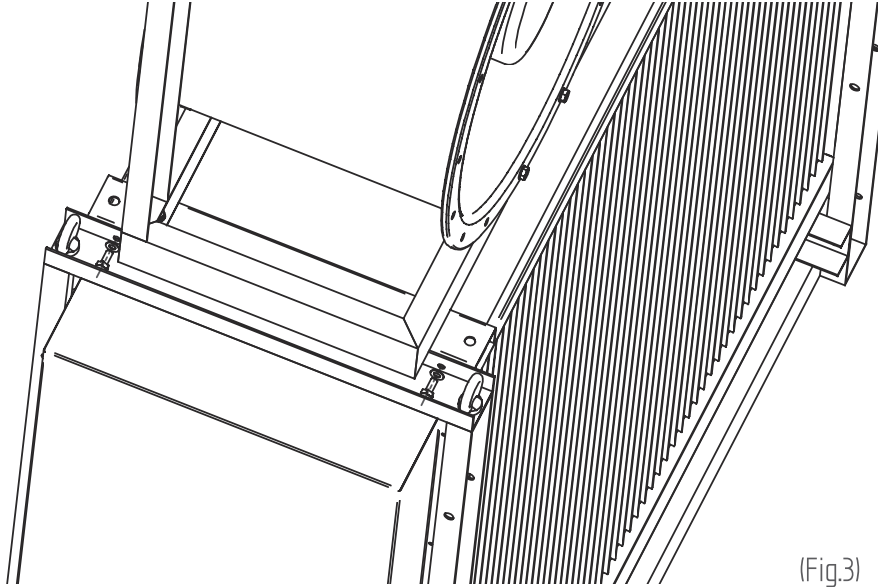

9. FIXATION AU PLAFOND DE LA PARTIE VENTILATION
GROUP FAN CEILING ATTACH
FIJACIÓN GRUPO DE VENTILADORES AL TECHO

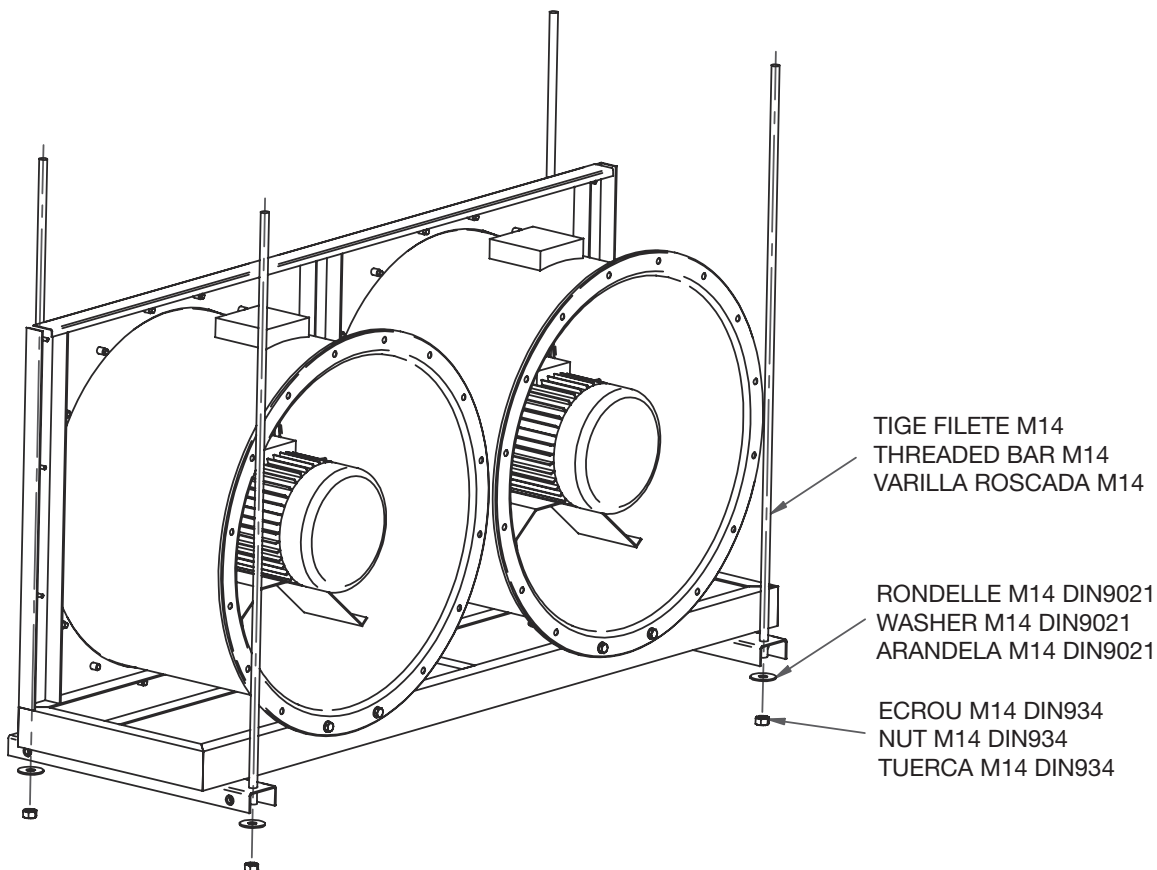

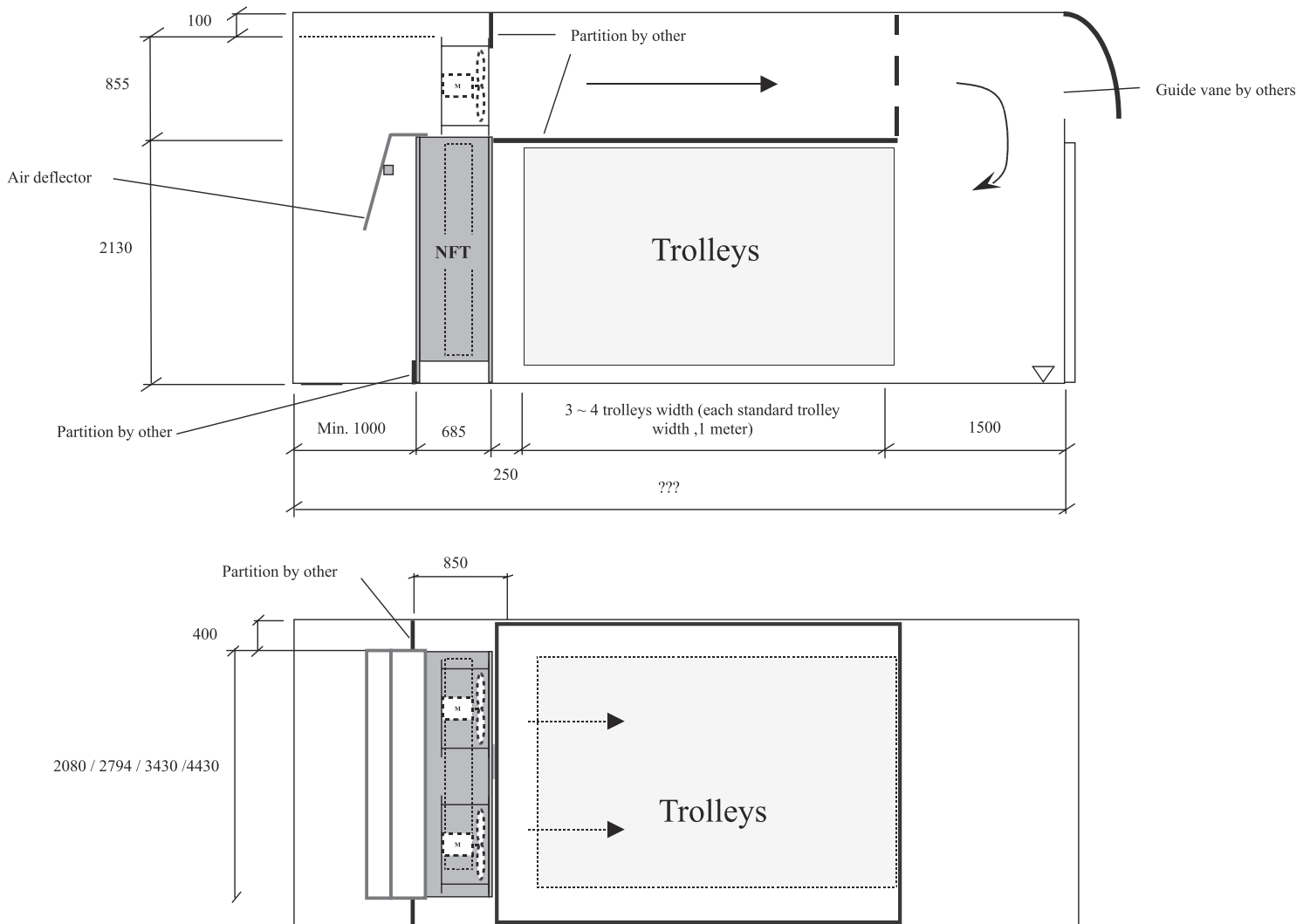

FRIGA-BOHN®



LFB France
 42 rue Roger Salengro - BP 205
 69741 GENAS CEDEX - FRANCE
 Tél. : +33 4 72 47 13 00 - Fax : +33 4 72 47 13 96
 www.frigabohn.com

Friga-Bohn se réserve le droit d'apporter toute modification sans préavis.
 Friga-Bohn reserves itself the right to make changes at any time without preliminary notice.
 Friga-Bohn Angaben und Abbildungen unverbindlich. Änderungen vorbehalten.
 Friga-Bohn se reserva el derecho de aportar cualquier modificación sin preaviso
 Friga-Bohn zastrzega sobie prawo do wprowadzania zmian bez uprzedzenia

NF
 Unit Coolers
 N° IN0019200-B
 04.2025